

HASTINGS

INSTRUMENTS

LOW CAPACITY FLOWMETERS AND CONTROLLERS

Models HFM-200, HFC-202

FEATURES

- $\pm 1\%$ of Full-Scale Accuracy
- Proven Reliability
- Range — 10 to 30,000 sccm (N₂ Equivalent)
- NIST Traceable Calibration

APPLICATIONS

- Leak Testing
- Medical Research
- Vapor Deposition
- R&D and Process Flows
- Semiconductor Processes
- Pollution Monitoring
- Gas Blending
- Chromatography



HFM-200 / HFC-202

DESIGN FEATURES

The Hastings Instruments Model HFM Mass Flowmeter and HFC Mass Flow Controller represent over 50 years of experience in designing and manufacturing reliable, high quality mass flow instruments.

The HFM/HFC Series of flow instruments is based on a modular design. At the heart of each instrument is an insulated thermo electric sensor which provides enhanced zero stability and allows installation in any orientation plane. This sensor is designed to be removable/replaceable in the field to virtually eliminate long down time due to clogging, the most common cause of failure in the industry. Additionally, the HFM/HFC design features an integral filter and an easily replaceable closed loop electronics card.* The HFC also features an externally adjustable valve with easily replaceable flow orifices.

All of these standard features, when coupled with the instrument's inherent linear response to flow changes and Hastings Instruments' long-proven reputation for quality, result in the finest flowmeters and flow controllers available today.

Optional Features

- Fittings
- O Ring seals
- Enhanced response time
- Enhanced EMF stability
- High pressure rating (1000 psig)
- 4-20 mA converters
- Cleaned for oxygen service

Accessories

- Power supplies/readouts
- Flow totalizers
- Alarm set points
- Interconnecting cables

*Note: After changing components, instruments require recalibration to meet accuracy specifications.



TELEDYNE
ELECTRONIC TECHNOLOGIES
Hastings Instruments
A Teledyne Technologies Company

MODELS HFM-200, HFC-202

SPECIFICATIONS HFM-200

Accuracy and Linearity	±1% F.S.
Repeatability	±0.05% F.S. typical
Standard Pressure Rating	500 psig
Pressure Coefficient	-0.005%/psi (0-500 psig N ₂) typical
High-Pressure Option	Proof tested to 1500 psig
Leak Integrity	< 1x10 ⁻⁹ sccs
Temperature Coefficient	±0.03%/°C (15-45°C) typical ±0.05%/°C (0-50°C) typical
STP	0°C and 760 Torr
Power	±15 VDC at ± 25 mA
Flow Signal	(inherently linear) 0-5.00 VDC
Wetted Material	316 SS, Viton®, 87/13 Au/Ni Braze
Connector	15-pin subminiature D
Fittings	1/4-in. Swagelok® tube
Weight (approx.)	1.8 lb (0.82 kg)

SPECIFICATIONS HFC-202

Accuracy and Linearity	±1% F.S.
Repeatability	±0.05% F.S. typical
Std. Pressure Rating	500 psig
High Pressure Option	Proof tested to 1500 psig
Pressure Coefficient	-0.005%/psi (0-500 psig N ₂) typical
Control Valve DP*	10 to 50 psid
Leak Integrity	< 1x10 ⁻⁹ sccs
Temperature Coefficient	±0.03%/°C (15-45°C) typical ±0.05%/°C (0-50°C) typical
STP	0°C and 760 Torr
Power	±15 VDC at +50 mA/-200 mA In valve over-ride: ±15 VDC at +65 mA/-220 mA
Flow Signal	(inherently linear) 0-5.00 VDC
Command Ref. Signal	0-5.00 VDC
Wetted Material	316 SS, Nickel, Viton, 87/13 Au/Ni Braze
Connector	15-pin subminiature D
Fittings	1/4 In. Swagelok
Weight (approx.)	1.8 lb (0.82 kg)

*Consult factory for other pressures.

Model HFM-200

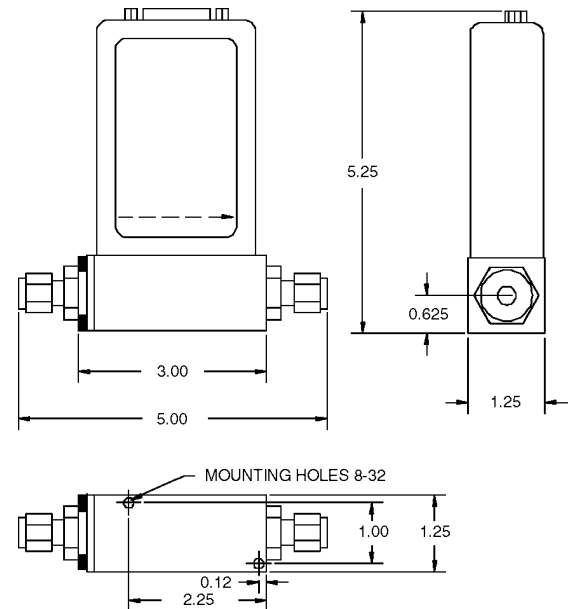

Model HFC-202

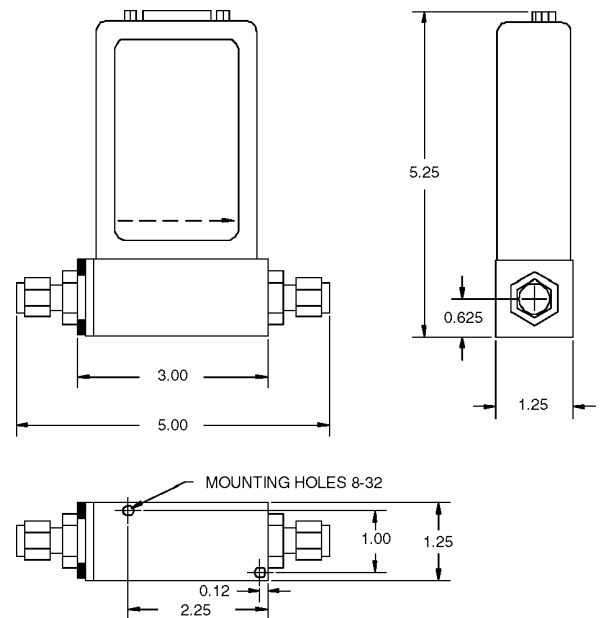

All dimensions shown are in inches

Selection Chart

Typical instrument ordering/options number:

Model No.	Circuit Board	Output	Fittings	O-Rings	Working Pressure	Calibration Type
HFM-200	01	02	01	01	01	01

Order No.	Options
Circuit Board	
01	Standard
02	Fast Response
Output	
01	0-5 Volts (Standard)
02	4-20mA
Fittings	
01	1/4" Swagelock (Std)
02	1/8" Swagelock
03	VCR® 1/4"
04	VCO® 1/4"
05	1/4" Elbow
06	No Fittings

Order No.	Options
O-Rings	
01	Viton (Standard)
02	Kalrez®
03	Neoprene
Working Pressure	
01	500 psig (Standard)
02	1000 psig
Calibration Type	
01	NIST 5 Point (Standard)
02	NIST 10 Point
03	NIST 20 Point

Range Information

Flow Units _____

Gas _____

Standard Conditions* _____

*Referenced to standard temperature and operating pressure (0°C and 760 Torr, respectively).

Selection Chart

Typical instrument ordering/options number:

Model No.	Circuit Board	Output	Fittings	O-Rings	Working Pressure	Calibration Type
HFC-202	01	01	01	01	01	01

Order No.	Options
Circuit Board	
01	Standard
Output	
01	0-5 Volts (Standard)
02	4-20mA Output
03	4-20mA I/O
Fittings	
01	1/4" Swagelock (Std)
02	1/8" Swagelock
03	VCR 1/4"
04	VCO 1/4"
05	1/4" Elbow
06	No Fittings

Order No.	Options
O-Rings	
01	Viton (Standard)
02	Kalrez
03	Neoprene
Working Pressure	
01	500 psig (Standard)
02	1000 psig
Calibration Type	
01	NIST 5 Point (Standard)
02	NIST 10 Point
03	NIST 20 Point

Range Information

Flow Units _____

Gas _____

Standard Conditions* _____

Upstream Pressure _____

Downstream Pressure _____

*Referenced to standard temperature and operating pressure (0°C and 760 Torr, respectively).

MODELS HFM-200, HFC-202

Your Customer Service Representative



TELEDYNE
ELECTRONIC TECHNOLOGIES
Hastings Instruments

A Teledyne Technologies Company

Telephone: (757) 723-6531

Toll Free: (800) 950-2468

Fax: (757) 723-3925

World Wide Web: <http://www.hastings-inst.com>

E-mail: hastings_instruments@teledyne.com

P.O. Box 1436

Hampton, VA 23661