

HASTINGS

INSTRUMENTS

METALINE™

Models HFM-300, HFC-302

FEATURES

- $\pm 0.75\%$ of Full-Scale Accuracy @ 3 Sigma
- All-metal Seals
- Settling Times:
HFM-300 0.50 sec
HFC-302 0.75 sec
- Range — 5 to 30,000 sccm (N₂ Equivalent)
- Large Diameter Sensor Tube
- Low Wetted Surface Area
- Operating Pressures to 500 psi or higher
- NIST Traceable Calibration

APPLICATIONS

- Leak Testing
- Research
- Vapor Deposition
- R&D and Process Flows
- Semiconductor Processes
- Pollution Monitoring
- Gas Blending
- Chromatography



HFM-300



HFC-302

DESIGN FEATURES

Hastings Instruments products represent over 50 years of experience in the design and manufacture of mass flow products. The all-metal seal 300 Series Metaline is a culmination of this experience with patented technologies that make these instruments the finest flowmeters and controllers available today.

The Hastings Mass Flow 300 Metaline Series meters and controllers are designed to accurately measure mass flow without corrections or compensations for gas pressure and temperature. They are accurate to better than $\pm 0.75\%$ at 3 sigma. Hastings mass flow instruments do not require any periodic maintenance under normal operating conditions with clean gases. No damage will occur from the use of moderate overpressures (~500 psi) or overflows. Instruments are normally calibrated with the appropriate standard calibration gas (nitrogen), then a correction factor is used to adjust the output for the intended gas. Special calibrations for other gases, such as oxygen, helium and argon, are available upon special order.

These products contain a number of features that set them apart from other available instruments: (1) They are inherently linear; no linearization circuitry is employed. Should recalibration in the field be desired (a calibration standard is required), the customer needs to simply set the zero and span points. (2) The output signal is linear for very large overflows and will not come back on scale when a flow an order of magnitude over the full scale flow rate is measured. (3) The HFM-300 incorporates a removable/replaceable sensor module.

MODELS HFM-300, HFC-302

DESIGN FEATURES (cont)

(4) The sensor tube is less likely to be clogged due to its large internal diameter (0.026"). (5) The low differential pressure drop across the flowmeter is ideal for leak detection applications. (6) The unit has very fast settling times and low thermal drift.

Optional Features

Fittings—VCR, VCO and Swagelok®
High pressure rating (1000 psig)
Cleaned for oxygen service

Accessories

Power supplies/readouts
Flow totalizers
Alarm set points
Interconnecting cables

*Note: After changing components, instruments require recalibration to meet accuracy specifications.

COMMON SPECIFICATIONS HFM-300/HFC-302

Accuracy	± 0.75% of F.S. @ 3 sigma
Repeatability	± 0.07% of F.S.
Maximum Operating Pressure	500 psi
High-Pressure Option	1000 psi (proof tested to 1500 psi)
Pressure Coefficient (Span)	0.01%/psi (N ₂)(0-50 psig)
Leak Integrity	< 1x10 ⁻⁹ sccs He
Temperature Coefficient (zero)	< 0.10%/°C of F.S. (0-60°C)
Temperature Coefficient (span)	< 0.03%/°C of reading (15-50°C)
Standard Flow Ranges	5, 10, 20, 50, 100, 200, 500 sccm 1, 2, 5, 10 slpm (N ₂ equivalent)
Standard Output	0-5 VDC
Optional Output	4-20 mA
Connector	15-pin subminiature D
*Attitude Sensitivity of Zero	< 0.7% of F.S.
*Attitude Sensitivity of Span	< 0.05% of reading

*N₂ @ 19.7 psia

SPECIFICATIONS HFM-300

Settling Time	0.3 sec (0% to 100% F.S.) (0-10 slm) 0.5 sec (0% to 100% F.S.) (0-30 slm)
Power Requirement	+15 VDC @ 55 mA to -15 VDC @ 50 mA
Wetted Materials	316L SS, Nickel 200, 302 SS**
Weight (approx.)	1.95 lb (0.9 kg)

SPECIFICATIONS HFC-302

Settling Time	0.75 sec (10% to 100% F.S.)
Power Requirement	± 15 VDC @ 150 mA
Wetted Materials	316L SS, Nickel 200, 302 SS**, Kalrez® (valve seat)
Setpoint Input	0-5 VDC (standard)/4-20 mA (optional)
Weight (approx.)	2.45 lb (1.1 kg)

**Flow rates > 10 slm

Hastings Instruments reserves the right to change or modify the design of its equipment without any obligation to provide notification of change or intent to change.

Kalrez® is a registered trademark of Dupont Dow Elastomers L.L.C.
Swagelok® is a registered trademark of Crawford Company.
VCR® is a registered trademark of Cajon Company.
VCO® is a registered trademark of Cajon Company.

Model HFM-300

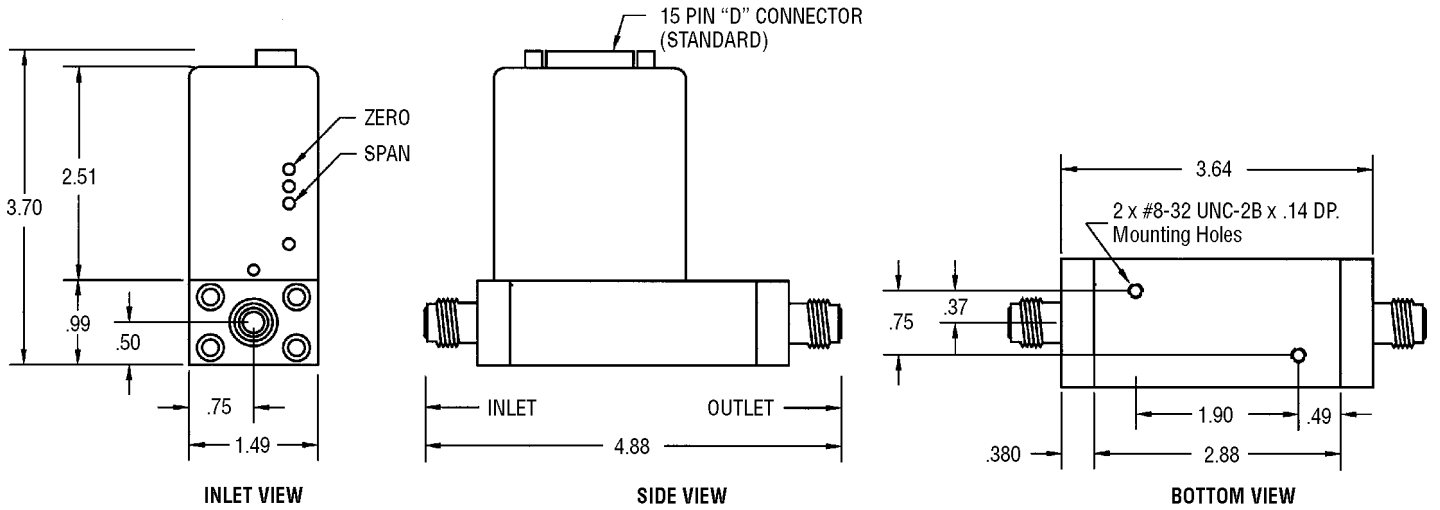

Model HFC-302

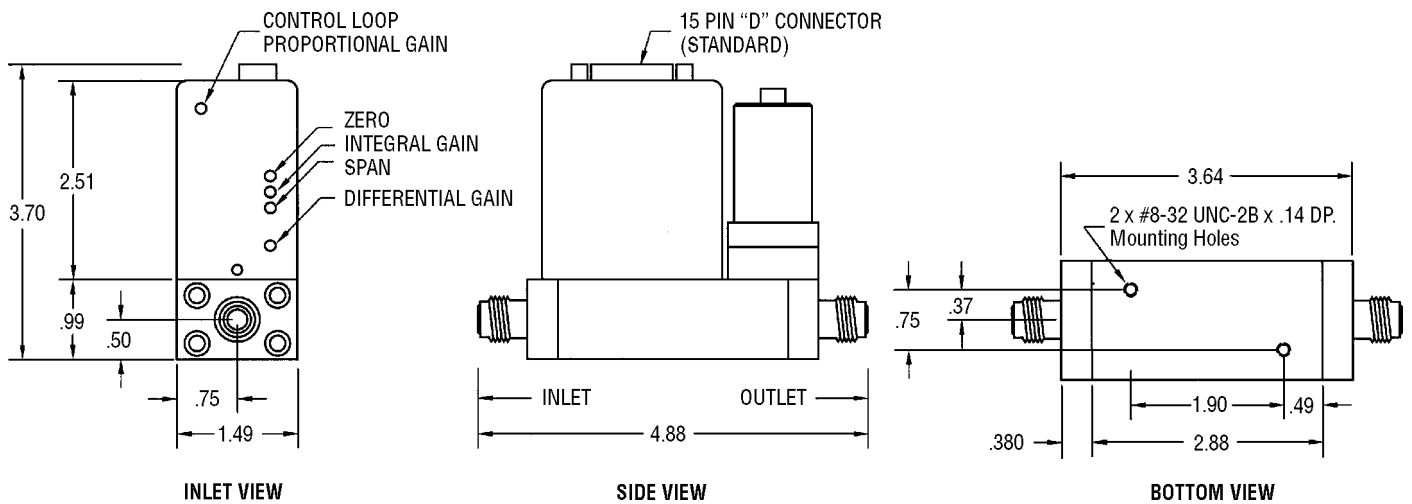

MODELS HFM-300, HFC-302

Selection Chart

Typical instrument ordering/options number:

Model No.	Circuit Board	Output	Fittings	Pressure	Calibration Type
HFM-300	02	01	01	01	01

Order No.	Options
Circuit Board	
01	Pinout H
02	Pinout U
03	Pinout M
Output	
01	0-5 Volts (Standard)
02	4-20mA

Order No.	Options
Fittings	
01	1/4" VCR®
02	1/4" Swagelok
03	1/8" Swagelok
04	1/4" VCO®
Pressure	
01	500 psi (Standard)
02	1000 psi (1500 proof)

Order No.	Options
Calibration Type	
01	NIST 5 Point
02	NIST 10 Point
03	NIST 20 Point
04	Curve

Range Information
 Range _____
 Flow Units _____
 Gas _____
 Standard Conditions* _____
 *Referenced to standard temperature and operating pressure (0°C and 760 Torr, respectively).

Selection Chart

Typical instrument ordering/options number:

Model No.	Circuit Board	Output	Fittings	Pressure	Calibration Type
HFC-302	02	01	01	01	01

Order No.	Options
Circuit Board	
01	Pinout H
02	Pinout U
03	Pinout M
Output	
01	0-5 Volts (Standard)
02	4-20mA
03	I/O 4-20mA
Fittings	
01	1/4" VCR®
02	1/4" Swagelok
03	1/8" Swagelok
04	1/4" VCO®
05	Threaded End Cap

Order No.	Options
Pressure	
01	500 psi (Standard)
02	1000 psi (1500 proof)
Calibration Type	
01	NIST 5 Point
02	NIST 10 Point
03	NIST 20 Point
04	Curve

Range Information
 Range _____
 Flow Units _____
 Gas _____
 Upstream Pressure _____
 Downstream Pressure _____
 Is downstream pressure dependent on flow resistance? Y/N _____
 Standard Conditions* _____
 *Referenced to standard temperature and operating pressure (0°C and 760 Torr, respectively).

Your Customer Service Representative



Telephone: (757) 723-6531
 Toll Free: (800) 950-2468
 Fax: (757) 723-3925
 World Wide Web: <http://www.hastings-inst.com>
 E-mail: hastings_instruments@teledyne.com
 P.O. Box 1436
 Hampton, VA 23661