

Chambers & Weldments

Section Seven

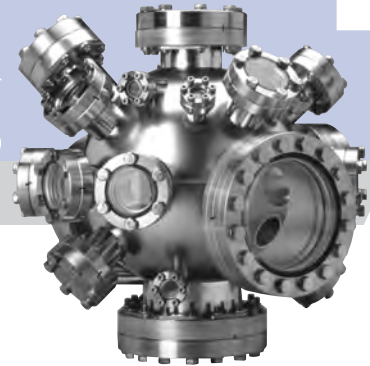

| | | |
|------------|---|-----------|
| 7.1 | General Information | 2 |
| 7.2 | Guide to Vacuum Chamber Design | 5 |
| 7.3 | Bell Jars, Feedthrough Collars & Baseplates | 8 |
| 7.4 | Surface Analysis Chamber | 9 |
| 7.5 | GEC Reference Cell | 10 |
| 7.6 | Weldments | 11 |
| 7.7 | Vacuum Chamber Gallery | 12 |

Nor-Cal Products, Inc.
1967 So. Oregon
Yreka, CA 96097 USA

Tel: **800-824-4166**
or 530-842-4457
Main Fax: 530-842-9130
Sales Fax: 530-841-9189
www.n-c.com





Chambers & Weldments

General Information

Nor-Cal Products has earned a reputation as a world-class manufacturer of high and ultra-high vacuum chambers. The quality, appearance and performance of our chambers are unequalled. We supply single chambers designed from customer specifications for university or national laboratory research projects, as well as production quantity chambers that are built-to-print for equipment manufacturers. Thin-film deposition and compound semiconductor processing are common applications for our high-vacuum, O-ring sealed chambers that operate at pressures down to 1×10^{-9} Torr. Vacuum fired 316L stainless steel, electropolishing and metal seals are recommended for ultra-high vacuum surface science chambers that operate at pressures in the 1×10^{-11} Torr range. Nor-Cal can fabricate vacuum chambers up to approximately 5 x 5 feet with doors, stands, water jackets and Mumetal shields. (Consult the factory for exact capabilities.) We offer a complete line of vacuum chamber accessories that include load locks, sample transfer and positioning devices, liquid and electrical feedthroughs, viewports and roughing components.

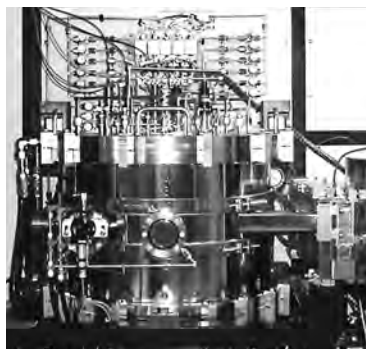

MOCVD reactor chamber



Vacuum coating chamber

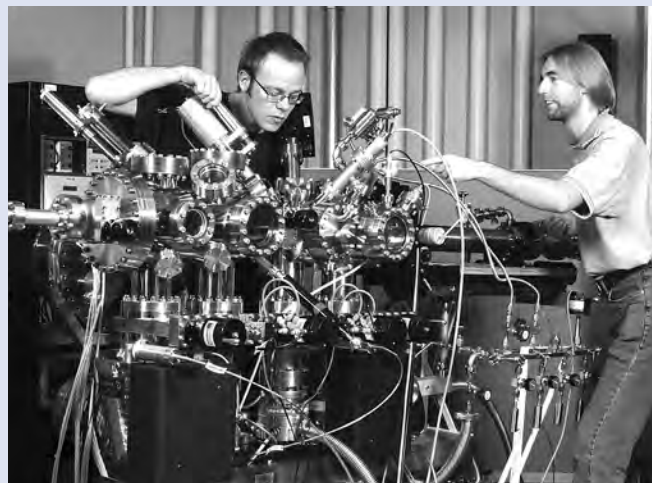

"The system utilizes several types of analyzers around the analysis chamber. Designed to be ergonomic and user-friendly, the system's frame components are on the floor level, maximizing accessibility to the research instruments. Electropolished 316L vacuum fired stainless steel was selected for the chambers in order to obtain a base pressure less than 3×10^{-11} mbar. Based on previous projects, we selected Nor-Cal Products to manufacture the vacuum chambers and components. We are very pleased with their quality, service and on-time delivery."

Jan-Olof Forsell

Design Manager, Gammadata Scientia and SSRL

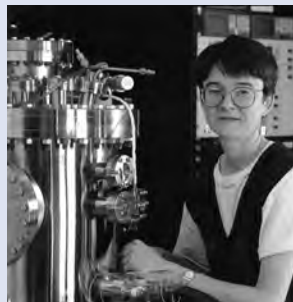

"I would like to reiterate how impressed we've been by the professional service we've received from Nor-Cal Products. I've interacted with engineers and salespeople from many vacuum equipment suppliers. It never fails to surprise me how uneven the service is. Salespeople are often uncommunicative, giving the impression that they're not in the least bit interested in your business, and technical people often don't know their products. It's incredibly refreshing, therefore, to interact with people, such as those at Nor-Cal, who are both courteous and well informed."

Susan Watson, PhD

Department of Physics,
University of California, San Diego



"This vacuum system was optimized for investigations into the magnetic properties of a wide range of materials using soft x-rays from synchrotron radiation sources. For such work, ultra high vacuum is necessary and this Nor-Cal Products chamber has a base pressure of 5×10^{-11} mbar after baking. The use of independent rotary stages for positioning of the sample and in-vacuum electromagnet provide a very high degree of flexibility by allowing any combination of sample surface and applied field relative to the incident soft x-rays."

Dr. Jonathan Hunter-Dunn

MAX-Lab
Lund University, Sweden

All dimensions are in inches
unless otherwise noted

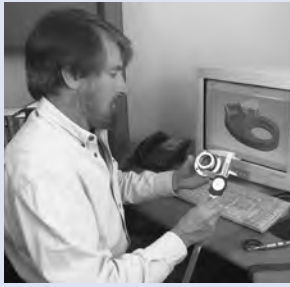
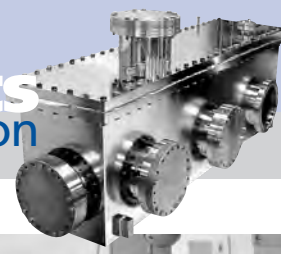

Engineering

As part of our commitment to quality and customer satisfaction, Nor-Cal's engineering staff thoroughly reviews each custom vacuum component for manufacturability before the production process begins. All customers benefit from the combined experience of our engineers, whose input during the design and production phase often results in cost savings and a superior product. Questions regarding design, specifications and testing are directed back to the customer for final approval.

Our engineers design from customer specifications, sketches or drawings and oversee custom component production using existing tooling and facilities. For our customers who do not have drafting personnel available and require a complex assembly, we can provide complete CAD drawings for approval after receipt of order. Nor-Cal's engineering department employs the latest versions of SolidWorks™ drafting and solid modeling software. Drawings may be e-mailed direct to our engineering department at prints@n-c.com. Acceptable file formats are IGES, SAT and STEP. You may also request CAD drawings and download 3D models of our most commonly used standard components from our website.

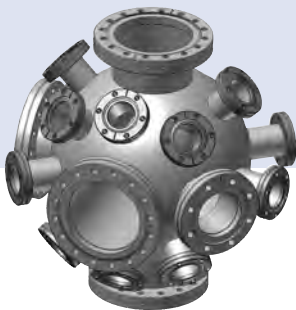

Manufacturing

Machining procedures are consistent with good UHV practices. Machine coolant is sulfur-free to reduce outgassing. All Nor-Cal components are designed to minimize entrapments that cause virtual leaks under vacuum. State-of-the-art CNC machining equipment is used to produce parts with consistently high quality.

GTAW fusion welding is used exclusively for a vacuum-tight metal bond. Purging with an inert gas reduces or eliminates oxygen entrapment and carbide precipitation that cause outgassing. Whenever possible welds are made on the inside, or are full penetration to eliminate entrapments and virtual leaks. External stitch welds are used in conjunction with internal vacuum welds for structural reinforcement, as necessary.

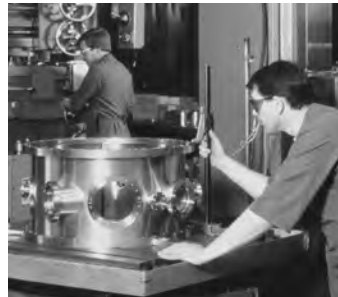

Materials

Nor-Cal Products uses 304 stainless steel tubing, spheres or roll-ups to fabricate vacuum vessels; however, 304L, 316, 316L or 316LN stainless steel can also be supplied. We have found that optimal vacuum performance can be obtained by using 2B rolled sheet with no secondary grinding for the body followed by electropolishing after ports are welded. Normally our standard material is dual certified 304/304L low carbon range stainless steel.

Flanges and baseplates are made from 304 stainless steel that has been specially treated to remove impurities inherent in 300 series steels. Special UHV-flanges 4 1/2 inches OD and smaller can be made from 304 electroslag remelt (ESR) bar stock. ESR is a refining process that produces stainless steel with higher purity, fewer inclusions and more uniform grain structure to eliminate microscopic leak paths.

Our standard flange material is certified to meet ASTM A-240 and has less than 0.01% sulfur to prevent sulfur stringers. Grain size is 3 to 6 per ASTM E-112. Maximum inclusion size is 2.5 per ASTM E-45. Roll-forged rings, Mumetal, aluminum and other materials can be supplied upon request.



Cleaning

A biodegradable detergent is used to remove machine lubricants before the parts are washed and rinsed with deionized water. Nor-Cal offers in-house bead blasting, chem cleaning and electropolishing of vacuum chambers. Glass shot cleans, hones, polishes and peens while removing scale. Some customers request bead blast on the exterior of the chamber with electropolish on the interior.



Electropolishing is considered the most desirable cleaning and surface conditioning process for stainless steel vacuum chambers. It is an electrochemical process that benefits the finished part in a number of ways simultaneously. Deburring, passivation and stress relieving are achieved while the machine-produced surface roughness is eroded. Electropolishing attacks the microscopic "peaks" of the surface more rapidly than the "valleys"; thereby maintaining critical dimensions while improving surface finishes. Normally .0003 to .0004 inches would be removed to lower the microfinish from 32 to 8 RMS. Electropolishing a 2B stainless steel rolled sheet achieves approximately a 90% reduction in surface area. This is most important for vacuum chambers because it produces faster pumpdown

and a lower base pressure. In addition to the improved mechanical properties of the surface, iron is removed electrochemically. This leaves the surface rich in chromium and nickel, which have extremely low vapor pressures. The result is the lowest outgassing rates possible from stainless steel. Having an in-house facility allows Nor-Cal to do multi-step electropolish in order to reduce "shadowed" areas on chambers with difficult geometries. Our electropolish tanks can accommodate chambers up to 60 x 50 x 65 inches.

All stainless steel parts are descaled and passivated in an acid solution to remove weld scale and other oxide layers. This process leaves the surface free from most contaminants that might impact the vacuum environment or promote intergranular corrosion. (Contact our factory for Ion Chromatography (I.C.) test data.) Chem cleaning can be used as a final cleaning step for chambers up to 35 x 53 x 33 inches to remove organic and metallic contaminants. The chamber is immersed in a series of controlled chemical baths and deionized water rinses and dried using filtered air. Chem cleaning results in the cleanest surface possible for ultra high vacuum components. (Contact our factory for I.C. test data.)

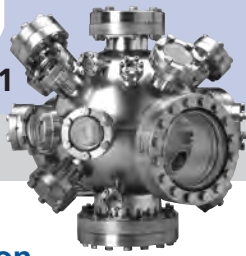

Inspection

Nor-Cal uses the most up-to-date equipment and procedures for the inspection of vacuum chambers. Every weld is leak checked with a helium mass spectrometer to insure leak rates of 1×10^{-9} mbar l/sec. or less. Mechanical inspection is accomplished with a coordinate measuring machine (CMM). We can provide our customers with CMM inspection reports of their chambers on request.

Our chamber qualification and test equipment is available to customers for an additional fee who request residual gas analysis (RGA) scans and leak checks of their chamber after vacuum baking. The test equipment includes vacuum pumps, gauges, RGA, quartz heaters, nitrogen back fill and a leak detector. Chamber bake out is achieved with high intensity infrared radiant lamps that are strategically placed throughout the chamber. Baking under vacuum removes high and low molecular weight volatile compounds. Non-water cooled UHV chambers are typically baked for at least 24 hours at 150°C . (The maximum temperature of system components such as seals, chamber materials, valves, etc. may limit maximum baking temperatures.)

Uniform bakeout temperature is achieved by wrapping the associated system components in high temperature fiberglass materials.

After cool down our RGA will provide partial pressure data, determining the level of residual volatile compounds. Typical scans produce atomic mass levels below 1×10^{-9} Torr for atomic masses greater than or equal to 44. Total system pressures are between 5×10^{-9} and 7×10^{-10} Torr. Chamber design, seals and pumps used, and the maximum bake temperature over time effect the residual gas composition and ultimate pressures reached. Following chamber scanning, chambers are leak tested using a NIST traceable helium mass spectrometer leak detector with a final allowable leak rate of 1×10^{-10} mbar l/sec. or less.



Mechanical inspection of process chamber with CMM (coordinate measuring machine)

Frames

Frames are usually constructed from $1\frac{1}{2}$ or 2 inch mild steel box tubing, which is powder coated. However, aluminum or a variety of other materials are available. In addition to leveling pads and castor wheels, we can design and fabricate frames with precision rotational and linear bearings for moving components, such as chamber lids. Integrated hoist assemblies, pump mounting, cabinets and panel rack mounting are also available.

System Integration

Nor-Cal can assemble an entire system including chamber, frame, pumps, gauges, valves, manipulators and other components to customer specifications in our 1,100 square foot, class 1000, final assembly area. After completion our vacuum technicians can complete a thorough system qualification, including bake out, RGA scan and leak check using the procedures described above. Additionally, a functional test is performed on all system hardware.

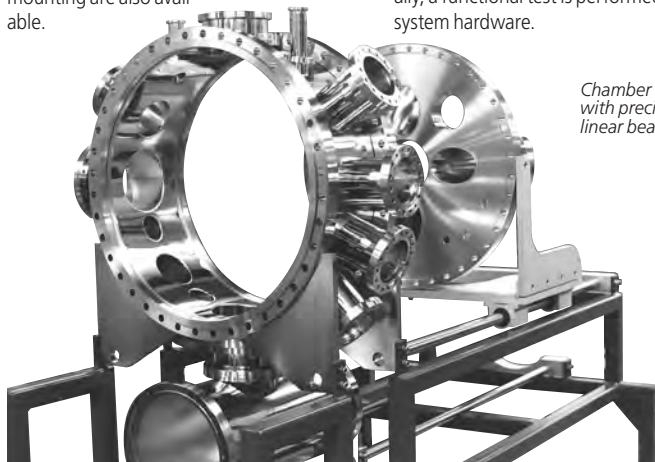

Chamber frame with precision linear bearings



Leak testing of chamber on chamber qualification test bench



System integration

Packaging

Vacuum chambers and other large components are packaged appropriately for truck, ship or airfreight to our customer's location. Unless specified otherwise, flanges are covered with aluminum foil to prevent internal contamination and scratching of the flange faces. Protective plastic covers are placed over the foil for additional protection. The chamber is then wrapped in 4 mil plastic and placed in a wooden crate. Foam is injected into plastic "pillows" which expand to fill the voids in the crate, suspending the chamber inside. Depending on customer specifications for systems, after qualification the chambers can be disassembled or purged with nitrogen gas, clean room packaged and shipped. Alternatively, some chambers have been packaged and shipped under vacuum.



The information presented on the following three pages is provided as a general guideline to the vacuum engineer or end user to aid in the design of their vacuum chamber. In addition to the specific areas which are discussed, these considerations should be addressed when designing a vacuum chamber:

| Chamber Material | Vacuum Level | Surface treatment | Special Requirements | Additional Hardware | Required Inspection Reports |
|--|--|--|--|--|--|
| 304SS, 304LSS, 316SS, 316LSS, aluminum, etc. | Base pressure and acceptable leak rate | Glass bead finish, electropolish, chemical clean, etc. | Vacuum bakeout, vacuum fire or RGA scan. | Blank-off flanges, manipulators, viewports, etc. | CMM inspection report printouts or certificate of conformance and/or material certificates |

By first determining the basic design parameters from those mentioned above, the actual process of designing, specifying and estimating the cost of your chamber will follow more smoothly. Nor-Cal sales estimators are available for any assistance you require. Engineering drawings can be e-mailed directly to prints@n-c.com.

Typical Chamber Configurations

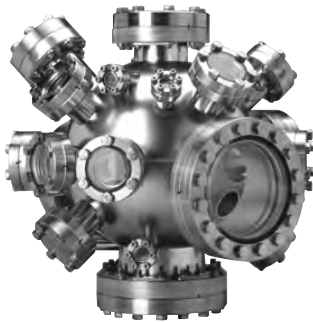

Spheres and Hemispheres

Spun hemispheres can be purchased in a wide range of standard sizes and welded together to form a spherical body. Often a large tube is attached to the bottom of the sphere for attachment of the pump. A number of smaller, radial ports can be positioned around the sphere for attachment of the load lock and various instruments. This is a common configuration for UHV analyzer chambers with a single target. This configuration is lighter, less expensive to manufacture and has less Internal volume than cylindrical configurations with machined lids.



Cylindrical

Cylindrical chamber bodies come in a variety of sizes and are made of tubing or roll-ups. The base plate and lid of the chamber can be made from die-formed dished heads, hemispheres or blank flanges. Dished heads and hemispheres are lighter and typically less expensive than machined flanges. This configuration is commonly used for analyzer chambers with multiple levels and targets, and for processing chambers with carousels or robotic arms.

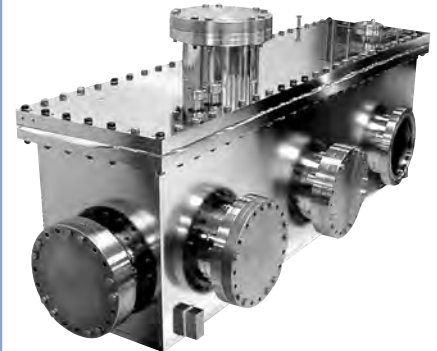

Rectangular

Rectangular chambers are generally more expensive than other configurations. However, they may be the preferred choice because of a requirement for accessibility, or when large chamber mass is required for vibration dampening. Rectangular chambers are fabricated from plate material that is welded, or they are machined from solid billets. Depending on material thickness and span, stiffening bars may be required to prevent deflection of the walls while the chamber is under vacuum.

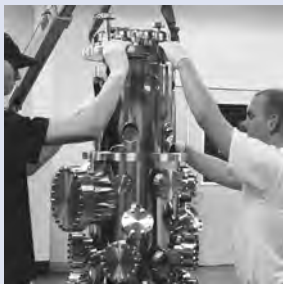

Double wall construction



Water channel construction

Water Cooled Chambers

Nor-Cal Products frequently provides water cooled chambers and flanges for diffusion, CVD, and other high temperature vacuum applications. Normally the construction techniques involve water channels or double walled construction. Water channels require considerable hand fitting and therefore tend to be more expensive than double walled construction. Double wall water-cooled chambers are fitted with internal baffles to provide consistent circulation throughout the chamber, resulting in excellent internal temperature uniformity.

Water-cooled chambers manufactured by Nor-Cal undergo a rigorous leak test to insure that they are free from water leaks. First the water cavities are stressed by pressurizing them with dry nitrogen. The water cavity is then pumped down with a helium leak detector, while helium is applied with a probe to all welds on the inside and outside of the chamber. (Consult the factory for pressure and integrity acceptance criteria.)

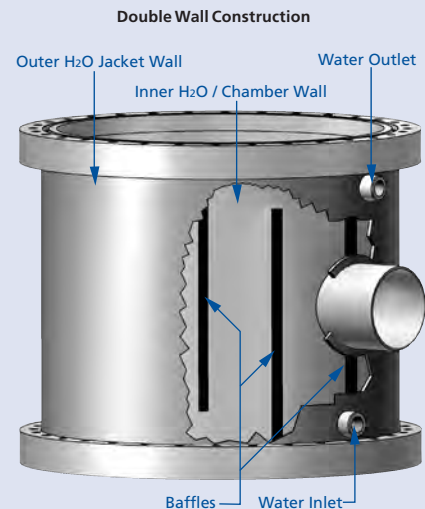



Chambers & Weldments

Guide to Vacuum Chamber Design

STANDARD CHAMBER DIMENSIONS

Nor-Cal can manufacture vacuum chambers with metric size tubes, roll-ups, and spheres, however inch sized materials are more readily available in the US and can be furnished for a lower price. For further clarification, contact an estimator at the factory or see our website.

Chamber Wall Thickness

Recommended minimum wall thicknesses are listed in the table below. Thicker walled material should be specified for chambers with ports having angular tolerances of less than $1/2^\circ$, or for processes that require large mass for vibration dampening.

| CHAMBER DIAMETER | WALL THICKNESS |
|----------------------|----------------|
| Under 17 inches | 0.120 |
| 17 through 28 inches | 0.188 |
| Over 28 inches | 0.250 |

Roll ups

Roll ups are formed from 2B rolled finish, flat sheet that is formed into a cylinder and stitch welded on the outside seam, before applying a vacuum weld to the inside. They can be obtained in a range of wall thicknesses and any diameters. Dished head and sphere diameters are typically available in the United States in nominal inch sizes.

Tubing

Nor-Cal stocks a broad variety of 304, 304L and 316L stainless steel tubing sizes that can be used for ports. Usually the port flange determines the diameter of the port tubing, but oversized tubing (i.e., $1\frac{3}{4}$ inch OD tubing for $2\frac{3}{4}$ inch OD CF flanges) is occasionally used for additional clearance for instrumentation. The table below lists common tubing sizes used for vacuum chamber ports.

| TUBE OD | TUBE ID | WALL THICKNESS |
|----------------|---------|----------------|
| $1/2$ | 0.402 | 0.049 |
| $3/4$ | 0.680 | 0.035 |
| 1 | 0.870 | 0.065 |
| $1\frac{1}{4}$ | 1.120 | 0.065 |
| $1\frac{1}{2}$ | 1.370 | 0.065 |
| $1\frac{5}{8}$ | 1.490 | 0.065 |
| $1\frac{3}{4}$ | 1.630 | 0.065 |
| 2 | 1.870 | 0.065 |
| $2\frac{1}{2}$ | 2.370 | 0.065 |
| 3 | 2.870 | 0.065 |
| 4 | 3.834 | 0.083 |
| 5 | 4.834 | 0.083 |
| 6 | 5.834 | 0.083 |
| 8 | 7.760 | 0.120 |
| 10 | 9.760 | 0.120 |
| 12 | 11.760 | 0.120 |



Port Lengths

Port lengths should be sufficiently long to allow the flange bolts to be inserted into the bolt holes from the underside of the flange unless tapped flanges are used. When designing chambers we typically dimension the ports so there is a minimum of three times the flange thickness from the port flange face to the outer wall of the chamber. If designing a chamber which utilizes NW clamps for assembly please refer to the chart below for clamp clearance details.

Standard Tolerances

Unless otherwise specified by the customer, standard tolerances will be adhered to during fabrication. These tolerances are acceptable for most analytical or process vacuum equipment and can normally be achieved without secondary machining operations after welding. Tighter tolerances required for specific applications are frequently provided for a slightly higher cost. Standard tolerances for machined dimensions are $\pm .005$ inches (although tolerances of $\pm .002$ inches are commonly held on critical flange dimensions). Standard tolerance for any welded dimension, such as a port length or chamber height up to 24 inches, is $\pm .020$ inches ($\pm .060$ inch for chambers >24 inches, but <72 inches in length). Standard tolerance for polar and azimuthal angles is $\pm 1/2^\circ$.

TOLERANCE MEASUREMENTS

| | |
|----------------------------|-----------------|
| Machined dimensions | ± 0.005 |
| Welded dimensions up to 24 | ± 0.020 |
| Welded dimensions over 24 | ± 0.060 |
| Focal length | ± 0.020 |
| Port alignments | $\pm 1/2^\circ$ |

NW Clamp Clearance

| FLANGE SIZE | Min. Dia. to Install A | Max. Dia. Closed B | Min. Dia. Closed C |
|-------------|------------------------|--------------------|--------------------|
| NW-10 | 2.86 | 2.65 | 1.75 |
| NW-16 | 2.86 | 2.65 | 1.75 |
| NW-25 | 3.32 | 3.00 | 2.24 |
| NW-40 | 4.00 | 3.72 | 2.90 |
| NW-50 | 5.45 | 4.62 | 3.69 |

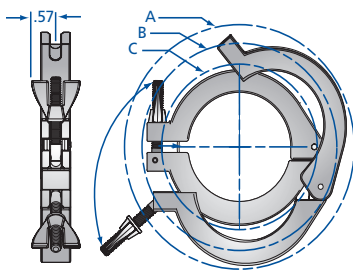

NW Bulkhead Detail

| FLANGE TYPE | BOLT CIRCLE | THREAD SIZE | THREAD DEPTH | BLIND TAPPED HOLES | THROUGH HOLE |
|-------------|-------------|-------------|--------------|--------------------|--------------|
| NW-16 | 1.50 | 10-32 | 0.300 | 6 | 0.90 |
| NW-25 | 1.89 | 10-32 | 0.300 | 6 | 1.26 |
| NW-40 | 2.44 | 10-32 | 0.300 | 6 | 1.84 |
| NW-50 | 3.25 | 10-32 | 0.300 | 8 | 2.35 |

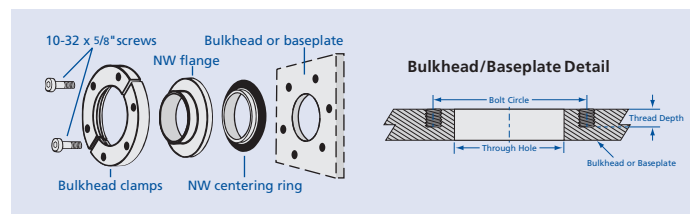

Bolt Pattern Orientation

Our components are manufactured with the primary axis straddling adjacent bolt holes on the mounting flange (American Standard). Most components can be furnished with the axis passing through a bolt hole axis (European Standard) on request. Leak check groove orientation should be indicated on drawings if critical.

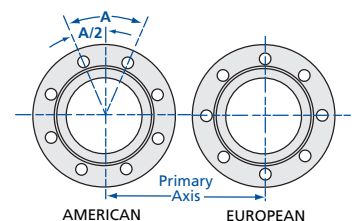



Chambers & Weldments

Bell Jars, Feedthrough Collars & Baseplates

SPECIFICATIONS

Materials

Flanges and body: 304 stainless steel
O-rings: Viton

Finish:

Beadblast standard
(Tumbled and electropolish available)

Fasteners: Wingnut, SureSeal,
bulkhead and EVAC clamps

Vacuum range

Elastomer seal: $\geq 1 \times 10^{-8}$ Torr -High vacuum
EVAC metal seal: $\geq 1 \times 10^{-11}$ Torr - UHV

Temperature range

Viton: -20°C to 200°C
Silicone: -50° to 230°C
Buna: -30°C to 110°C
EVAC metal seal: -270°C to 150°C



Nor-Cal offers stainless steel baseplates, feedthrough collars and bell jars as standard items. Used in conjunction with our other chamber accessories, an entire bell jar system can be ordered without the expense of design or custom fabrication. Any of the bell jar components shown may be altered to meet the customer's specific requirements. Our sales staff can quickly estimate the additional cost or savings.

Baseplates come in a variety of sizes with smooth faced ASA flanges to bolt directly to the vacuum pump. They may also be furnished with other types and sizes of flanges. If feedthroughs are required, a feedthrough collar with varying numbers of 2 3/4 inch CF flanges may be inserted between the baseplate and bell jar. NW flanges can also be provided. A dovetail O-ring groove on the base of the collar effects a seal with the baseplate when the Viton O-ring provided is compressed. The feedthrough collar can be used with a glass bell jar and L-gasket or our stainless steel bell jar with 7056 glass viewport. Like the collar, the bell jar is provided with a Viton O-ring and has a dovetail groove in its base. Bead-blasted finish is standard. Water-cooled jackets are available upon request.

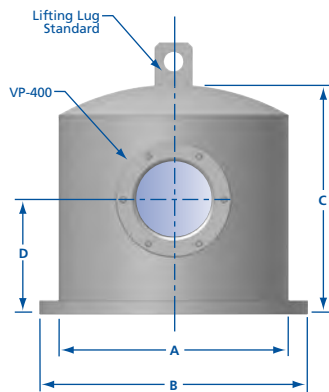

Bell Jars

| MODEL NUMBER | TUBE OD A | FLANGE OD B | C | D |
|--------------|--------------|----------------|-------|-------|
| BJ-1200 | 12 | 14 | 12.00 | 6.00 |
| BJ-1200-EP* | 12 | 14 | 12.00 | 6.00 |
| BJ-1800 | 18 | 20 | 30.00 | 12.00 |
| BJ-1800-EP* | 18 | 20 | 30.00 | 12.00 |
| BJ-2400 | 24 | 26 | 30.00 | 12.00 |
| BJ-2400-EP* | 24 | 26 | 30.00 | 12.00 |

NOTE: One Viton O-ring is included with all of the above.

*Electropolished finish.

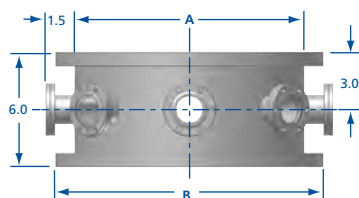

Feedthrough Collars

| MODEL NUMBER | NUMBER OF 2.75 CF PORTS | TUBE OD A | FLANGE OD B |
|-----------------|----------------------------|--------------|----------------|
| FCO-1200-6 | 6 | 12 | 14 |
| FCO-1200-6-EP* | 6 | 12 | 14 |
| FCO-1800-8 | 8 | 18 | 20 |
| FCO-1800-8-EP* | 8 | 18 | 20 |
| FCO-2400-12 | 12 | 24 | 26 |
| FCO-2400-12-EP* | 12 | 24 | 26 |

NOTE: One Viton O-ring is included with all of the above.

*Electropolished finish.

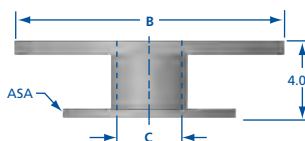

Baseplates

| MODEL NUMBER | NOMINAL SIZE | ASA FLANGE | FLANGE OD B | TUBE ID C |
|--------------|--------------|-------------|----------------|--------------|
| BP-1200 | 12 | ASA-9-400N | 14 | 3.83 |
| BP-1200-EP* | 12 | ASA-9-400N | 14 | 3.83 |
| BP-1800 | 18 | ASA-11-800N | 20 | 7.76 |
| BP-1800-EP* | 18 | ASA-11-800N | 20 | 7.76 |
| BP-2400 | 24 | ASA-11-800N | 26 | 7.76 |
| BP-2400-EP* | 24 | ASA-11-800N | 26 | 7.76 |

*Electropolished finish.

Replacement Viton O-Rings

MODEL NUMBER

1200-OR

1800-OR

2400-OR

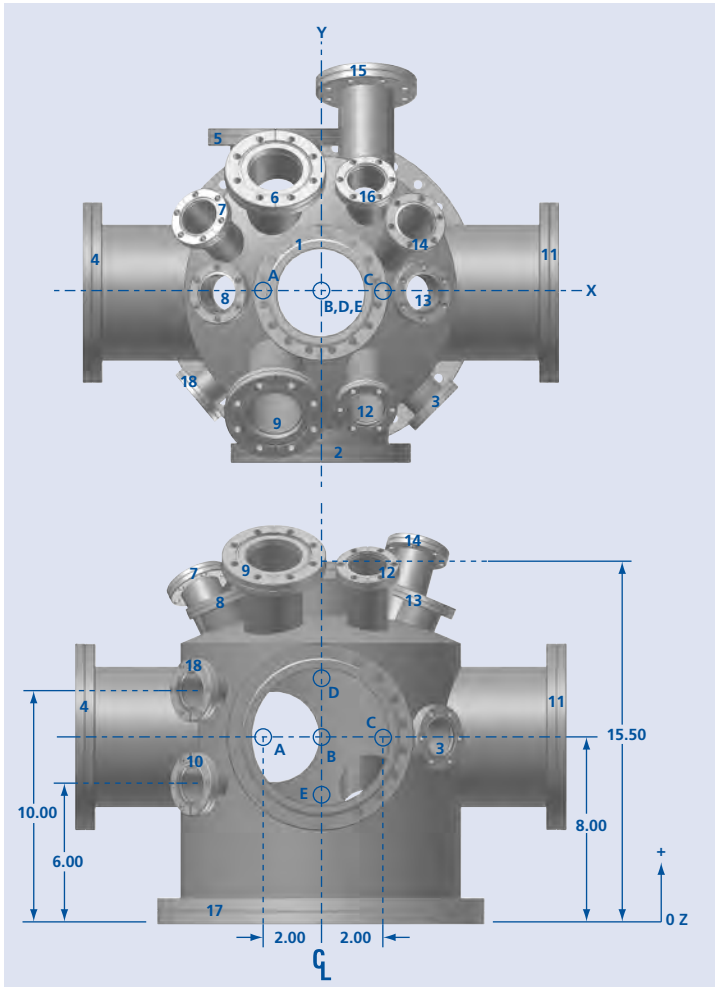
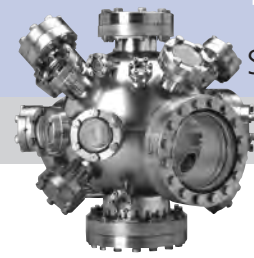

Nor-Cal offers a standard vacuum chamber, which incorporates the features required by many of our surface science customers at an affordable price. The chamber's geometry offers maximum flexibility, making it suitable for many types of studies and experiments. Seventeen ports can accommodate viewports, doors, feedthroughs, manipulators or analytical instruments. This design can be used as a platform and modified to meet your own specific requirements.

SPECIFICATIONS

Materials

Body and flanges: 304 stainless steel
Finish: Electropolished inside and out
Pump flange: 14^{5/8} inch female wire seal or 14 inch CF flange
Port tubing: Oversized 1^{3/4} on all 2^{3/4} CF flanged ports
Ports: 17, with CF flanges

Temperature range: ≤450°C.

Vacuum range: ≥10⁻¹⁰ Torr

Leak rate: ≤1 x 10⁻⁹ standard cc/sec.

Order Information

| MODEL NUMBER | PUMPING PORT FLANGE (PORT 17) |
|--------------|-------------------------------|
| SAC-12WS | 14.62 Female Wire Seal |
| SAC-12CF | 14.00 CF |

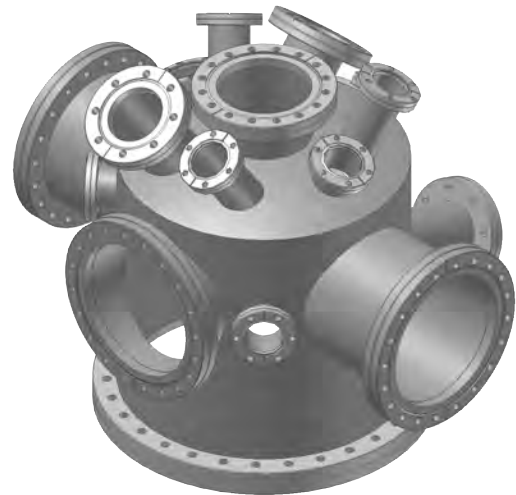

Surface Analysis Chamber Port Configuration

| PORT NUMBER | FLANGE TYPE | TUBE OD | TARGET POINT | FOCAL LENGTH | POLAR ANGLE |
|-------------|-----------------------|------------------|--------------|--------------|-------------|
| 1 | 6.00 CF | 4 | B (0,0,8) | 7.50 | 0° |
| 2 | 8.00 CF | 6 | B (0,0,8) | 7.50 | 90° |
| 3 | 2.75 CF | 1 ^{3/4} | B (0,0,8) | 7.25 | 90° |
| 4 | 8.00 CF | 6 | A (-2,0,8) | 8.50 | 90° |
| 5 | 6.00 CF | 4 | A (-2,0,8) | 7.25 | 90° |
| 6 | 4.50 CF | 2 ^{1/2} | A (-2,0,8) | 8.50 | 40° |
| 7 | 2.75 CF | 1 ^{3/4} | A (-2,0,8) | 8.25 | 35° |
| 8 | 2.75 CF | 1 ^{3/4} | A (-2,0,8) | 6.50 | 23° |
| 9 | 4.50 CF | 2 ^{1/2} | A (-2,0,8) | 9.50 | 35° |
| 10 | 2.75 CF | 1 ^{3/4} | E (0,0,6) | 7.25 | 90° |
| 11 | 8.00 CF | 6 | C (2,0,8) | 8.50 | 90° |
| 12 | 2.75 CF | 1 ^{3/4} | C (2,0,8) | 9.00 | 35° |
| 13 | 2.75 CF | 1 ^{3/4} | C (2,0,8) | 6.50 | 23° |
| 14 | 2.75 CF | 1 ^{3/4} | C (2,0,8) | 9.00 | 25° |
| 15 | 4.50 CF | 2 ^{1/2} | C (2,0,8) | 10.00 | 110° |
| 16 | 2.75 CF | 1 ^{3/4} | C (2,0,8) | 7.75 | 40° |
| 17 | 14.62 FWS or 14.00 CF | 12 | B (0,0,8) | 8.00 | 180° |
| 18 | 2.75 CF | 1 ^{3/4} | D (0,0,10) | 7.25 | 90° |



Chambers & Weldments

GEC Reference Cell

Detailed bill of materials and mechanical drawings of the GEC Reference Cell can be downloaded from the Vacuum Chambers section of our web site.
www.n-c.com

The design for this system was developed at the 1988 Gaseous Electronics Conference (GEC) for research projects utilizing radio frequency (rf) discharges in various gasses at a frequency of 13.56 MHz. The reference cell concept grew out of a need to provide an experimental platform for comparing plasma measurements carried out in a number of separate but identical chambers. The basic purpose of the reference cell is to provide a comparison between measurements performed on identical discharge sources by different groups to establish the necessary and sufficient conditions defining reproducible plasma parameters and establishing a reference rf-excited plasma that allows others to define and calibrate diagnostic measurements and theoretical models.

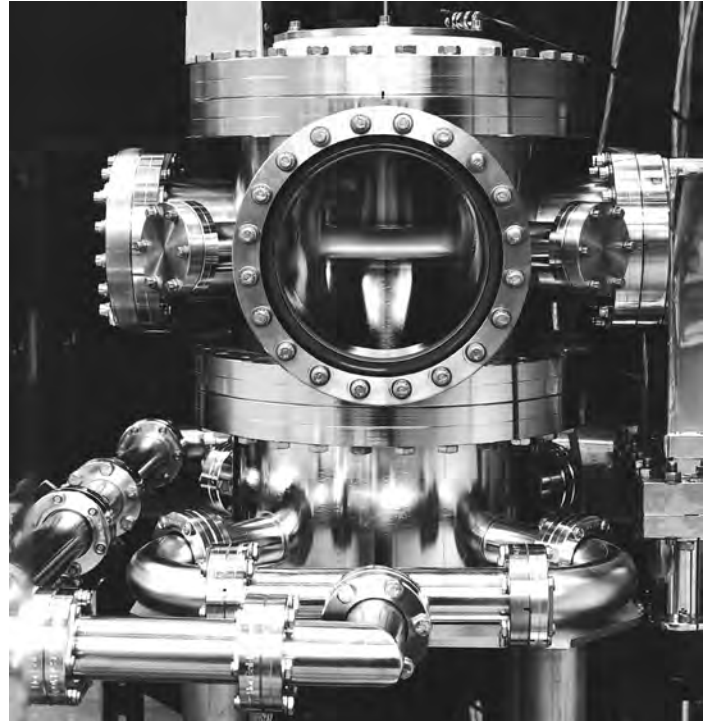

SPECIFICATIONS

Materials

Flanges and body: 304 stainless steel
 Flange type: CF
 Finish: Electropolished, inside and out

Vacuum range: $\geq 1 \times 10^{-10}$ Torr - UHV

Temperature range: -270°C to 450°C

The cell is a conventional, twelve-inch diameter, UHV chamber with a pair of 10 cm diameter, water-cooled, parallel plate electrodes. A unique pumpout well provides uniform pumping in the chamber. Since the reference cell's inception, Nor-Cal has worked with Sandia National Lab's design team in order to improve manufacturability and offer standard options requested by individual research groups. These options include: moveable upper electrode, RGA sampling port, wafer transfer, inductively coupled coil and heated annular ring.

GEC Reference Cell System Components

DESCRIPTION

- Plasma reactor chamber
- Pumpout weldment
- Non-moveable upper electrode assembly
- Moveable upper electrode assembly
- Lower electrode assembly
- Lower electrode (mass spectrometer test)
- Lower wafer transfer electrode
- Base weldment (aluminum)
- Lower pumping manifold assembly
- Inductive coil assembly
- Heated annular ring assembly with controller

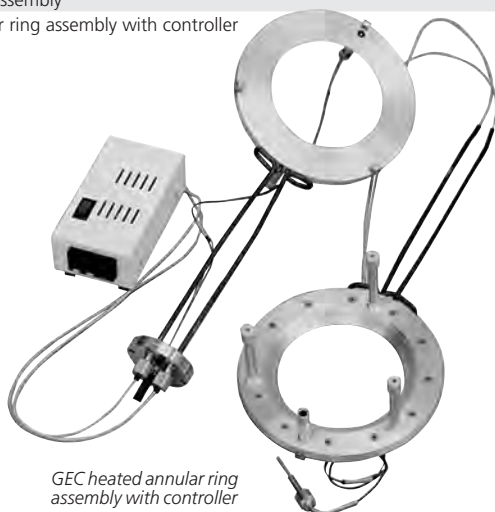

GEC heated annular ring assembly with controller

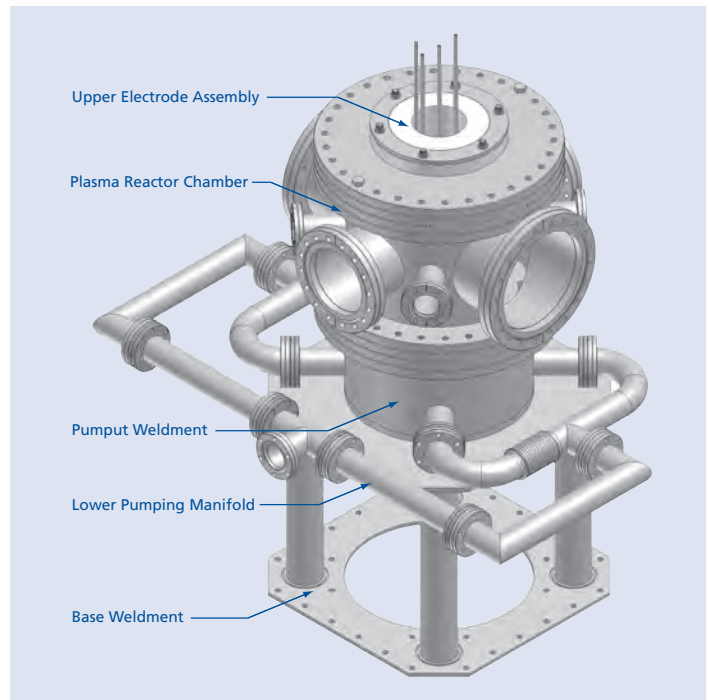

Chambers & Weldments

Custom Weldments



Because we manufacture tees, elbows and other weld fittings in-house, Nor-Cal can also fabricate exhaust weldments and other special assemblies for semiconductor equipment from a single piece of tubing by utilizing some or all of the techniques described below. Welds and other manufacturing steps are eliminated, improving cleanliness and fit while reducing cost. We have demonstrated as much as 30% savings to our customers using this technique.

SPECIFICATIONS

Materials

Tube ODs: 1/4 to 10 inch
 Tubes and flanges: 304 stainless steel
 (316L available on request)
 Finish: Electropolished or beadblasted
 Flange types: CF, NW, ISO, ASA and EVAC

Temperature range

Metal seal: -270°C to 450°C
 Elastomer seal: -20°C to 200°C

Vacuum range

Metal seal: $\geq 10^{-11}$ Torr - UHV
 Elastomer seal: $\geq 10^{-8}$ Torr - High Vacuum



CNC Tube Bending

Nor-Cal employs a computer numerically controlled (CNC) tube bender to form elbows and custom exhaust weldments. This enables us to quickly make multiple compound angle bends in a single piece of tubing, while holding .010 inch tolerance between bends. Alternate methods of fabrication require welding of several prefabricated parts, resulting in greater incidence of leaks and cumulative tolerance buildup. Using our method, several welds and other manufacturing steps are eliminated, improving cleanliness and fit while reducing cost. Nor-Cal has tooling for 3/4, 1, 1 1/2 and 2-inch tubing. Custom or metric tubing diameters are available upon request.



Ball Pulled Ports

Nor-Cal manufactures tees, crosses, valve bodies, ion pump bodies and custom exhaust weldments with ball pulled ports. A hydraulic press is used to pull a ball through a small opening in the tubing to create a smooth, crevice-free opening. The formed metal is then trimmed perpendicular to the centerline of the tube, allowing a straight tube to be welded to the port with a full penetration butt weld. Alternate methods of port fabrication require boring the hole, coping the end of the tube and welding from the outside. Nor-Cal can pull ports for 1/2 to 10 inch diameter tubing, while holding the true position of the port within .030 inch.



Orbital Welding

Inert environment orbital welding is also available for repeatable and precise full penetration flange-to-tube welds. This automated process eliminates the variables associated with hand welding, such as rotation speed and the width of the heat affected zone (HAZ). Orbital welding can be performed on any length tube with diameters from 1/8 to 4 inches.

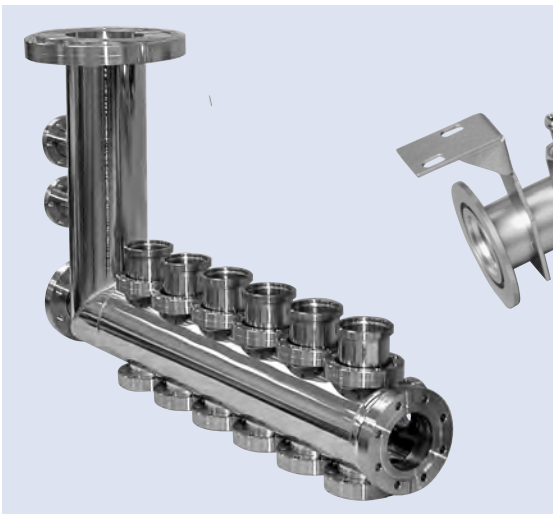

Chambers & Weldments

Vacuum Chamber Gallery

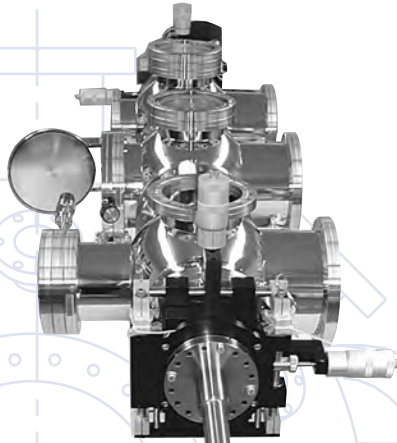

Multi-chamber custom research and development system consisting of three chambers and a variety of sample transfer and manipulation devices



Ultra-high vacuum research chamber



High vacuum chamber used to house an X-ray scanner in the Sandia National Laboratory LIGA project



Cornell University Physics Department surface science chamber

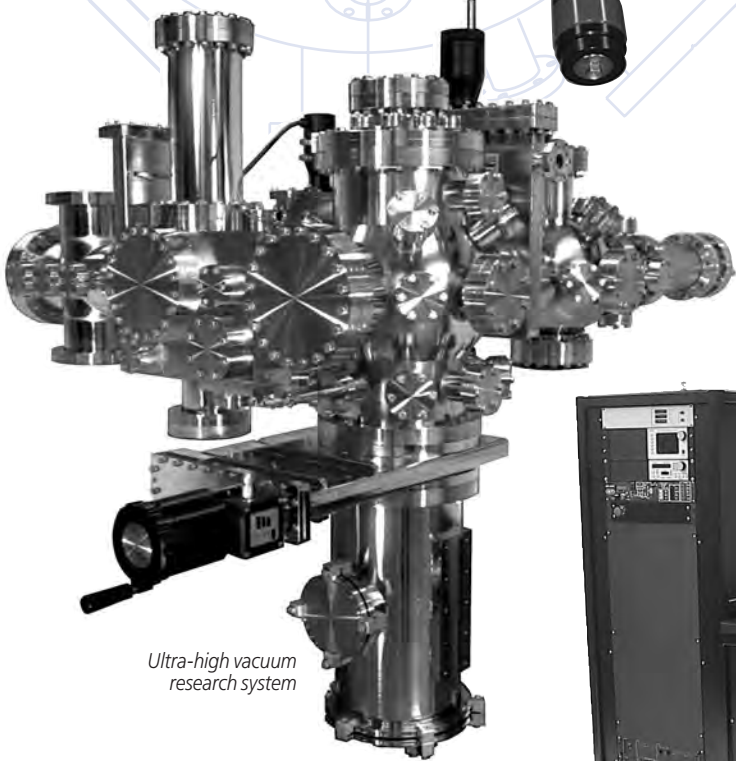

Ultra-high vacuum research system



Chamber with door manufactured for Edwards Air Force Base



Custom OLED (Organic Light Emitting Device) System by Trovato Mfg. Inc., incorporating a Nor-Cal high vacuum chamber



ESCA electron spectrometer