

# Foreline Traps

## Section Five

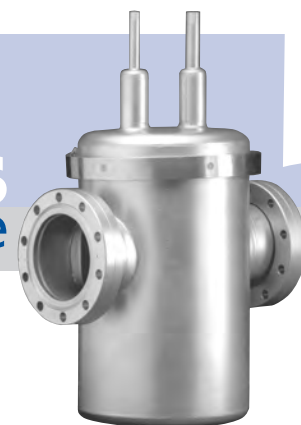

|            |                                 |           |
|------------|---------------------------------|-----------|
| <b>5.1</b> | General Information             | <b>2</b>  |
| <b>5.2</b> | Metal Sieve Traps               | <b>4</b>  |
| <b>5.3</b> | Molecular Sieve Traps           | <b>6</b>  |
| <b>5.4</b> | Particulate Traps               | <b>7</b>  |
| <b>5.5</b> | LPCVD-TEOS Traps                | <b>8</b>  |
| <b>5.6</b> | Water-Cooled Traps              | <b>9</b>  |
| <b>5.7</b> | Liquid Nitrogen Traps           | <b>10</b> |
| <b>5.8</b> | Oil Mist Eliminators            | <b>11</b> |
| <b>5.9</b> | Filters, Hardware & Accessories | <b>12</b> |

**Nor-Cal Products, Inc.**  
1967 So. Oregon  
Yreka, CA 96097 USA

Tel: **800-824-4166**  
or 530-842-4457  
Main Fax: 530-842-9130  
Sales Fax: 530-841-9189  
[www.n-c.com](http://www.n-c.com)



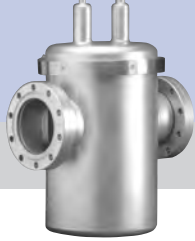

# Foreline Traps

## General Information



Custom water and metal sieve multistage trap



Electropolish finish is available on all traps

Since 1962, Nor-Cal Products has been designing and building standard and custom foreline traps for the vacuum industry. These traps range in complexity from the sealed coaxial traps, which prevent oil backstreaming, to the triple-pass water cooled traps, which remove condensable gases that contaminate mechanical pump oil or other parts of the system. Often times our customers see a 200% increase in preventative maintenance intervals after installing one of these traps.

All traps disassemble easily with a Viton O-ring and V-clamp, with the exception of our sealed coaxial metal sieve traps which have a one piece body. The two piece body allows for easy removal for cleaning or filter replacement.

The standard trap body finish is beadblast. Electropolish inside and out is available upon request. Electropolished traps are easier to clean because the surface is more highly polished than the standard beadblast finish. Nickleplating is also available for additional corrosion resistance.



TIG Fusion Welding

### Trap Selection Guide

| TRAP TYPE        | METAL SIEVE                        |                 | MOLECULAR | COLD    |                 | PARTICULATE      |           |            |
|------------------|------------------------------------|-----------------|-----------|---------|-----------------|------------------|-----------|------------|
|                  | FILTER MATERIAL                    | STAINLESS STEEL | COPPER    | ZEOLITE | LN <sup>2</sup> | H <sup>2</sup> O | POLYESTER | FIBERGLASS |
| TRAP APPLICATION | OIL BACKSTREAM                     | ••              | ••        | ••      | •••             |                  |           |            |
|                  | WATER VAPOR                        |                 |           | ••      | •••             |                  |           |            |
|                  | ORGANICS                           |                 |           |         | ••              | •                |           |            |
|                  | ACID VAPORS                        |                 |           |         | ••              |                  |           |            |
|                  | PARTICLES <149°C                   | •               | •         |         |                 |                  | •••       | •••        |
|                  | PARTICLES <370°C                   | •               | •         |         |                 |                  |           | •••        |
|                  | CONDENSIBLES - LOW VAPOR PRESSURE  | ••              | ••        |         | •••             | •••              |           |            |
|                  | CONDENSIBLES - HIGH VAPOR PRESSURE | •               | •         |         | •••             | •                |           |            |

Blank - Trap is not appropriate for this application • - Good performance for this application  
 •• - Better performance for this application ••• - Best performance for this application

### Semiconductor Process Temperature Guide

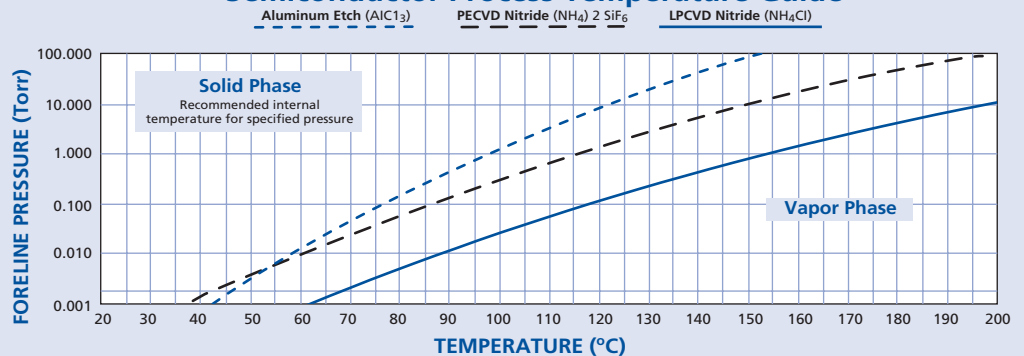

All dimensions are in inches unless otherwise noted

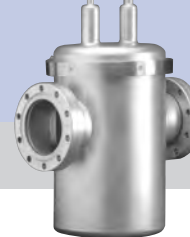

LPCVD/TEOS trap and a heated foreline

### Comprehensive Downstream Solutions

Our experience coupled with a broad product offering allows us to integrate components, providing comprehensive solutions to semiconductor fabs and equipment manufacturers. To improve overall system performance and achieve customer defined goals, a thorough evaluation of the system is conducted. A detailed worksheet is posted on our website for you to download. Answer these questions before calling your Nor-Cal representative. This worksheet will greatly assist us in calculating your cost of ownership model. A cost of ownership model can show payback as a result of increased tool utilization and decreased planned and unplanned maintenance costs. To download the worksheet, go to [www.n-c.com](http://www.n-c.com) and select Services.

Foreline traps, thermal products, Intellisys pressure control valves, Genesis soft start valves and weldments can be provided as turnkey modules. Thermal and vacuum characterization can be performed at Nor-Cal before the assembly is supplied, leak checked, blanked off and clean room packaged.

### Custom Foreline Traps

Standard trap designs are readily altered or custom models are designed and fabricated to improve performance for your specific application. Some examples are described below. Call for more information or to discuss your specific needs.

#### Liquid Recovery Traps

Nor-Cal has provided many types of condensation traps for liquid collection before they enter the pump. Often they have valves or drains to allow the liquid to be collected and reused. Some of the liquids collected include photoresist, oil and tantalum.

#### High Capacity Particulate Traps

Nor-Cal can provide high-capacity particle traps with multi-liter capacities for applications with large particle loads, such as silicon wafer processing.

#### High Capacity Water Cooled Traps

Semiconductor CVD equipment manufacturers require high wafer counts between preventative maintenance. Unlike other manufacturers who offer one solution to fit a number of applications, Nor-Cal will design high-capacity water-cooled traps to achieve specific customer-stated goals. Port geometry, capacity, conductance and efficiency are adjusted in order to produce the optimal design for the application. Examples of processes we have provided solutions for include TiN barrier layer deposition, LPCVD Nitride and III-Vs MOCVD.

#### Liquid Nitrogen Traps

High capacity liquid nitrogen traps can be furnished for customers who require larger LN<sup>2</sup> capacity to extend the time between refills or larger trapping capacity for condensable by-product.

#### Multistage Traps

Multistage traps can be furnished for processes that require a combination of trap media, such as water-cooling and particle filtration. The trap shown here was developed for a GaAs MOCVD process. The first stage particle filter removes heavy metals, while the water cooled second stage collects sulfur.



High capacity particulate trap

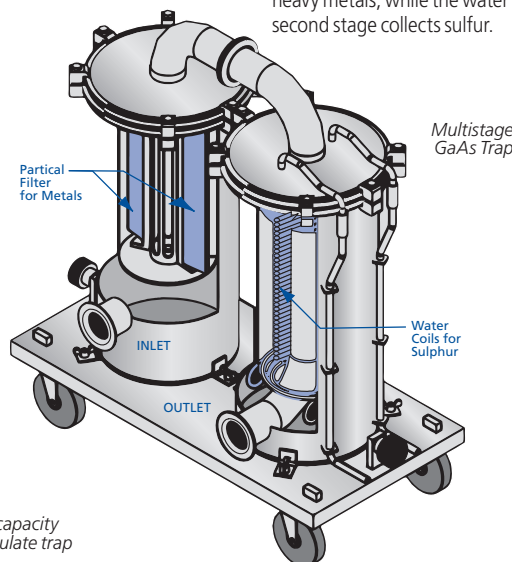

Multistage GaAs Trap

### Foreline Trap Options

When ordering a trap with options, please follow the option tree below. **Note:** All options are not available on some body sizes or trap types.

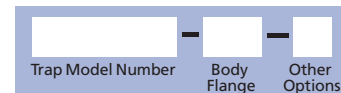

**Example:** FTPA-6-2002-NWB-BF-L7

#### Body Flange Option

| OPTION | FITS BODY OD |
|--------|--------------|
| -BF    | 4            |
| -BF    | 6            |
| -BF    | 8            |

These ISO clamp style flanges are an alternative to V-clamps. Not available on sealed coaxial metal traps, or 2" or 4 1/2" trap bodies.

#### Other Options

These options are trap type specific

#### Copper Sieve Option

| OPTION | FITS TRAP TYPE |
|--------|----------------|
| -CS    | Metal sieve    |

The standard metal sieve filter is stainless steel. Copper metal sieve filters are available at no additional cost for all sealed and two-piece metal sieve traps.

#### 240 Volt Heater Option

| OPTION | FITS TRAP TYPE  |
|--------|-----------------|
| -240V  | Molecular sieve |

The standard molecular sieve trap regeneration heater is 120V. 240V heaters are available as an option at no additional cost. Other voltages available.

#### Quick Disconnect Option

| OPTION | FITS TRAP TYPE |
|--------|----------------|
| -QD    | Water cooled   |

Immediately shuts off water flow from both directions for single-handed, no-spill removal of a water cooled trap from the system for preventative maintenance or O-ring replacement.

#### Fiberglass Particulate Filter Option

For temperatures up to 370°C

| OPTION | FITS TRAP TYPE |
|--------|----------------|
| -F     | Particulate    |

#### High Capacity Particulate Filter Option

| OPTION | FITS TRAP TYPE |
|--------|----------------|
| -L7    | Particulate    |

This fiberglass filter provides a reservoir for applications with heavy particle loads that might block the inlet.

# Foreline Traps

## Metal Sieve Traps



### SPECIFICATIONS

#### Material

Trap Body: 304 stainless steel  
Flanges: 304 stainless steel  
Sieve: 304 stainless steel

Vacuum range:  $\geq 1 \times 10^{-8}$  Torr

Temperature range: -20°C to 150°C

Options: Copper sieve filters, electropolish, ISO body flange

Nor-Cal metal sieve traps are provided with a fibrous stainless steel sieve for removal of hydrocarbons which backstream toward the chamber when the mechanical pump oil is at its vapor pressure. Copper sieve is available as an option at no additional cost. Add “-CS” to model number. The body flange option is also available for 4, 6 and 8 inch trap bodies. Add “-BF” to model number.

Standard designs include a sealed, single piece, coaxial body and a two-piece, clamped body with coaxial or right angle port configurations. The sealed trap design requires removal from the system before cleaning. The two-piece clamped body design makes disassembly, cleaning and sieve replacement a simple task. For proper sealing of two-piece body traps, apply a light coating of Krytox lube when cleaning or replacing the O-ring.

Standard body finish is beadblast. Electropolish finish, larger body sizes, CF, EVAC and ASA flanges are also available. Call for pricing.



### Sealed Coaxial Metal Sieve Traps

| MODEL NUMBER  | BODY OD | FLANGE TYPE | PORT OD | A     |
|---------------|---------|-------------|---------|-------|
| CT-2-0502-NWB | 2       | NW-10B      | 1/2     | 8.43  |
| CT-2-0752-NWB | 2       | NW-16B      | 3/4     | 8.43  |
| CT-2-1002-NWB | 2       | NW-25B      | 1       | 8.43  |
| CT-4-0752-NWB | 4       | NW-16B      | 3/4     | 10.30 |
| CT-4-1002-NWB | 4       | NW-25B      | 1       | 10.30 |
| CT-4-1502-NWB | 4       | NW-40B      | 1 1/2   | 10.30 |
| CT-4-2002-NWB | 4       | NW-50B      | 2       | 10.30 |

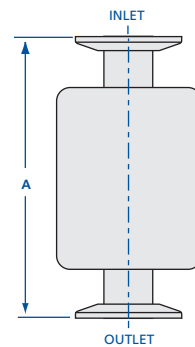

### Angle Metal Sieve Traps

| MODEL NUMBER   | DIAGRAM | BODY OD | FLANGE TYPE    | PORT OD | A     | B    | C    | D    |
|----------------|---------|---------|----------------|---------|-------|------|------|------|
| FTA-2-0502-NWB | A       | 2*      | NW-10B         | 1/2     | 6.94  | 3.56 | 5.38 | 2.65 |
| FTA-2-0752-NWB | A       | 2*      | NW-16B         | 3/4     | 6.94  | 3.56 | 5.25 | 2.65 |
| FTA-2-1002-NWB | A       | 2*      | NW-25B         | 1       | 6.94  | 3.56 | 5.13 | 2.65 |
| FTA-4-0752-NWB | B       | 4       | NW-16B         | 3/4     | 8.65  | 4.80 | 6.67 | 3.65 |
| FTA-4-1002-NWB | B       | 4       | NW-25B         | 1       | 8.65  | 4.80 | 6.55 | 3.65 |
| FTA-4-1502-NWB | B       | 4       | NW-40B         | 1 1/2   | 8.65  | 4.80 | 6.29 | 3.65 |
| FTA-4-2002-NWB | B       | 4       | NW-50B         | 2       | 8.65  | 4.80 | 6.04 | 3.65 |
| FTA-6-1502-NWB | B       | 6       | NW-40B         | 1 1/2   | 8.65  | 6.90 | 5.15 | 4.65 |
| FTA-6-2002-NWB | B       | 6       | NW-50B         | 2       | 8.65  | 6.90 | 4.90 | 4.65 |
| FTA-6-3002-ISO | B       | 6       | ISO-80-300-OF  | 3       | 8.75  | 6.90 | 4.87 | 4.75 |
| FTA-6-4002-ISO | B       | 6       | ISO-100-400-OF | 4       | 8.75  | 6.90 | 4.56 | 4.75 |
| FTA-8-2002-NWB | B       | 8       | NW-50B         | 2       | 11.65 | 9.00 | 7.78 | 5.65 |
| FTA-8-3002-ISO | B       | 8       | ISO-80-300-OF  | 3       | 11.75 | 9.00 | 7.38 | 5.75 |
| FTA-8-4002-ISO | B       | 8       | ISO-100-400-OF | 4       | 11.75 | 9.00 | 6.88 | 5.75 |

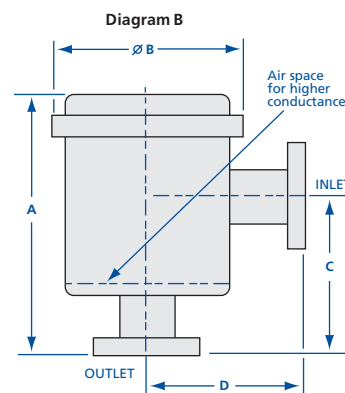
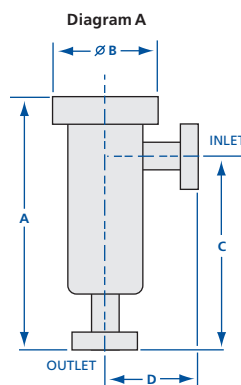



### Coaxial Metal Sieve Traps

| MODEL NUMBER   | DIAGRAM | BODY OD | FLANGES        | PORT OD | A     | B    |
|----------------|---------|---------|----------------|---------|-------|------|
| FCT-2-0502-NWB | A       | 2*      | NW-10B         | 1/2     | 8.50  | 3.56 |
| FCT-2-0752-NWB | A       | 2*      | NW-16B         | 3/4     | 8.50  | 3.56 |
| FCT-2-1002-NWB | A       | 2*      | NW-25B         | 1       | 8.50  | 3.56 |
| FCT-4-0752-NWB | B       | 4       | NW-16B         | 3/4     | 10.30 | 4.80 |
| FCT-4-1002-NWB | B       | 4       | NW-25B         | 1       | 10.30 | 4.80 |
| FCT-4-1502-NWB | B       | 4       | NW-40B         | 1 1/2   | 10.30 | 4.80 |
| FCT-4-2002-NWB | B       | 4       | NW-50B         | 2       | 10.30 | 4.80 |
| FCT-6-1502-NWB | B       | 6       | NW-40B         | 1 1/2   | 10.30 | 6.90 |
| FCT-6-2002-NWB | B       | 6       | NW-50B         | 2       | 10.30 | 6.90 |
| FCT-6-2502-ISO | B       | 6       | ISO-63-250-OF  | 2 1/2   | 10.50 | 6.90 |
| FCT-6-3002-ISO | B       | 6       | ISO-80-300-OF  | 3       | 10.50 | 6.90 |
| FCT-6-4002-ISO | B       | 6       | ISO-100-400-OF | 4       | 10.50 | 6.90 |
| FCT-8-2002-NWB | B       | 8       | NW-50B         | 2       | 13.30 | 9.00 |
| FCT-8-2502-ISO | B       | 8       | ISO-63-250-OF  | 2 1/2   | 13.50 | 9.00 |
| FCT-8-3002-ISO | B       | 8       | ISO-80-300-OF  | 3       | 13.50 | 9.00 |
| FCT-8-4002-ISO | B       | 8       | ISO-100-400-OF | 4       | 13.50 | 9.00 |

\* ISO body flange option not available for 2 inch trap bodies

#### SPECIFICATIONS

##### Material

Trap Body: 304 stainless steel  
Flanges: 304 stainless steel  
Sieve: 304 stainless steel

**Vacuum range:**  $\geq 1 \times 10^{-8}$  Torr

**Temperature range:** -20°C to 150°C

**Options:** ISO body flanges, copper sieve filters, electropolish

#### Copper Sieve Option

Add option suffix to trap model number.

##### OPTION

-CS

The standard metal sieve filter is stainless steel. Copper metal sieve filters are available at no additional cost for all sealed and two-piece metal sieve traps.

#### Body Flange Option

Add option suffix to trap model number.

##### OPTION FITS BODY OD

|     |   |
|-----|---|
| -BF | 4 |
| -BF | 6 |
| -BF | 8 |

These ISO clamp style flanges are an alternative to V-clamps. Not available on sealed coaxial metal or 2" traps.

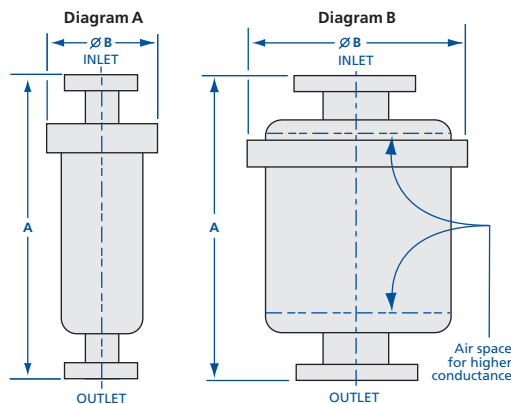

Metal sieve cartridges

Replacement filters and other hardware are located on Page 166



# Foreline Traps

## Molecular Sieve Traps



### SPECIFICATIONS

#### Material

Body: 304 stainless steel  
Flanges: 304 stainless steel  
Desiccant: Zeolite 13X, 1/8" pellets

**Vacuum range:**  $\geq 1 \times 10^{-8}$  Torr

**Temperature range:** -20°C to 150°C

**Options:** 240V regeneration heaters and ISO body flanges See page 175

These traps perform a dual function. A zeolite desiccant removes hydrocarbons which backstream toward the chamber when the mechanical pump oil is at its vapor pressure. Also, the zeolite traps water vapor and other gasses before they reach the mechanical pump and contaminate the pump oil. Depending on the process, this can reduce the oil change frequency significantly.

Nor-Cal's molecular sieve trap utilizes the two-piece trap design for ease of maintenance and zeolite replacement. For maximum conductance the sieve material is contained in a suspended basket fabricated from perforated 304 stainless steel. This design provides conductance to the sieve at the top of the basket as well as around the periphery. A mid-basket baffle causes the gas to enter one-half of the basket and to exit the other half.

When initializing a trap, replacing the sieve or when base pressure cannot be achieved, the sieve should be regenerated by turning on the heater for a few hours and running the mechanical pump with its ballast valve open. The frequency and duration of sieve regeneration is dependent upon the kind and amount of gasses produced by the particular application. To replace the sieve, remove the trap end that contains the heater and remove the nut at the end of the basket. Dump the expired sieve material, replace with new, reattach the basket/end plate then perform the regeneration process outlined above.

A molecular sieve charge and regeneration heater are included with every trap. 240V regeneration heater is available as an option. Other voltages and wattages are available upon request. The heater is held in place with a clip that allows trap mounting in any position. Standard finish is beadblasted. Electropolish finish, other body and flange configurations, and larger body sizes are available.

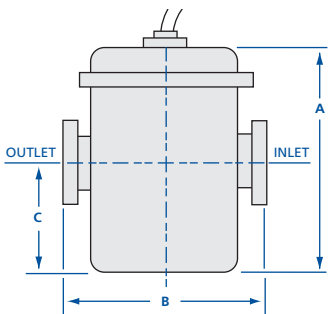
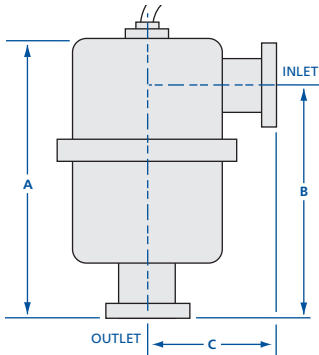
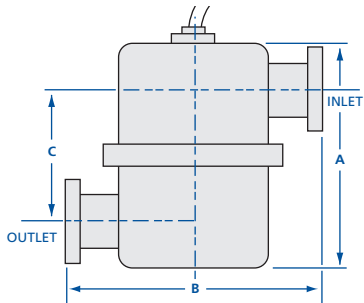
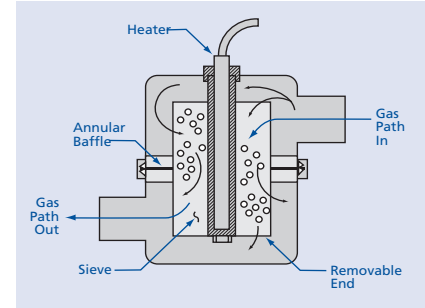

### In-Line Molecular Sieve Traps

| MODEL NUMBER   | BODY OD | FLANGE TYPE    | PORT OD | REGENERATION HEATER RATING* | A     | B     | C    |
|----------------|---------|----------------|---------|-----------------------------|-------|-------|------|
| FTM-4-0752-NWB | 4       | NW-16B         | 3/4     | 120V / 125W                 | 6.20  | 7.30  | 3.50 |
| FTM-4-1002-NWB | 4       | NW-25B         | 1       | 120V / 125W                 | 6.20  | 7.30  | 3.50 |
| FTM-4-1502-NWB | 4       | NW-40B         | 1 1/2   | 120V / 125W                 | 6.20  | 7.30  | 3.50 |
| FTM-6-1502-NWB | 6       | NW-40B         | 1 1/2   | 120V / 230W                 | 8.10  | 9.30  | 4.10 |
| FTM-6-2002-NWB | 6       | NW-50B         | 2       | 120V / 230W                 | 8.10  | 9.30  | 4.10 |
| FTM-8-2002-NWB | 8       | NW-50B         | 2       | 120V / 350W                 | 13.00 | 11.30 | 6.75 |
| FTM-8-2502-ISO | 8       | ISO-63-250-OF  | 2 1/2   | 120V / 350W                 | 13.00 | 11.50 | 6.75 |
| FTM-8-3002-ISO | 8       | ISO-80-300-OF  | 3       | 120V / 350W                 | 13.00 | 11.50 | 6.75 |
| FTM-8-4002-ISO | 8       | ISO-100-400-OF | 4       | 120V / 350W                 | 13.00 | 11.50 | 6.75 |

### Angle Molecular Sieve Traps

| MODEL NUMBER    | BODY OD | FLANGE TYPE    | PORT OD | REGENERATION HEATER RATING* | A     | B     | C    |
|-----------------|---------|----------------|---------|-----------------------------|-------|-------|------|
| FTMA-4-0752-NWB | 4       | NW-16B         | 3/4     | 120V / 125W                 | 7.85  | 6.55  | 3.65 |
| FTMA-4-1002-NWB | 4       | NW-25B         | 1       | 120V / 125W                 | 7.85  | 6.55  | 3.65 |
| FTMA-4-1502-NWB | 4       | NW-40B         | 1 1/2   | 120V / 125W                 | 7.85  | 6.55  | 3.65 |
| FTMA-6-1502-NWB | 6       | NW-40B         | 1 1/2   | 120V / 230W                 | 9.75  | 7.75  | 4.65 |
| FTMA-6-2002-NWB | 6       | NW-50B         | 2       | 120V / 230W                 | 9.75  | 7.75  | 4.65 |
| FTMA-8-2002-NWB | 8       | NW-50B         | 2       | 120V / 350W                 | 14.65 | 11.53 | 5.65 |
| FTMA-8-2502-ISO | 8       | ISO-63-250-OF  | 2 1/2   | 120V / 350W                 | 14.75 | 11.63 | 5.75 |
| FTMA-8-3002-ISO | 8       | ISO-80-300-OF  | 3       | 120V / 350W                 | 14.75 | 11.63 | 5.75 |
| FTMA-8-4002-ISO | 8       | ISO-100-400-OF | 4       | 120V / 350W                 | 14.75 | 11.63 | 5.75 |

### Straight-In-Line Molecular Sieve Traps

| MODEL NUMBER    | BODY OD | FLANGE TYPE    | PORT OD | REGENERATION HEATER RATING* | A     | B     | C    |
|-----------------|---------|----------------|---------|-----------------------------|-------|-------|------|
| FTMS-4-0752-NWB | 4       | NW-16B         | 3/4     | 120V / 125W                 | 7.00  | 7.30  | 3.50 |
| FTMS-4-1002-NWB | 4       | NW-25B         | 1       | 120V / 125W                 | 7.00  | 7.30  | 3.50 |
| FTMS-4-1502-NWB | 4       | NW-40B         | 1 1/2   | 120V / 125W                 | 7.00  | 7.30  | 3.50 |
| FTMS-6-1502-NWB | 6       | NW-40B         | 1 1/2   | 120V / 230W                 | 7.00  | 9.30  | 3.50 |
| FTMS-6-2002-NWB | 6       | NW-50B         | 2       | 120V / 230W                 | 7.00  | 9.30  | 3.50 |
| FTMS-8-2002-NWB | 8       | NW-50B         | 2       | 120V / 350W                 | 10.00 | 11.30 | 5.00 |
| FTMS-8-2502-ISO | 8       | ISO-63-250-OF  | 2 1/2   | 120V / 350W                 | 10.00 | 11.50 | 5.00 |
| FTMS-8-3002-ISO | 8       | ISO-80-300-OF  | 3       | 120V / 350W                 | 10.00 | 11.50 | 5.00 |
| FTMS-8-4002-ISO | 8       | ISO-100-400-OF | 4       | 120V / 350W                 | 10.00 | 11.50 | 5.00 |

### \*240 Volt Heater Option

240V heaters are available as an option at no additional cost. Other voltages available. Add option suffix to the end of the trap model number

| OPTION | DESCRIPTION |
|--------|-------------|
| -240V  | 240V heater |



Regeneration heater and Zeolite charge

Replacement charges, heaters & other hardware are located on Page 166

# Foreline Traps

## Particulate Traps

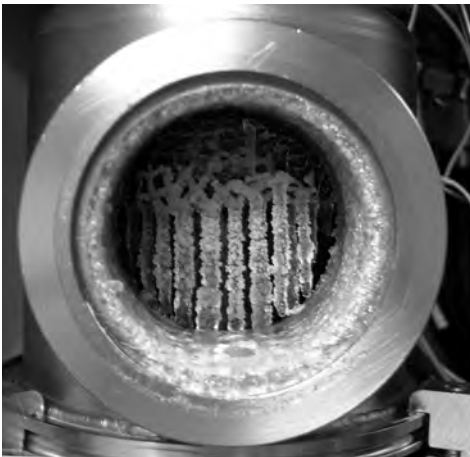

These traps remove particles that might enter the mechanical pump and contaminate the oil. Standard traps include a polyester felt filter traps particles over 10 microns in size at 98% efficiency. Filters can be cleaned with a vacuum cleaner. Suitable for process temperatures from ambient to 149°C. Filters with other micron ratings are available upon request.

Woven, 10 micron fiberglass filters are available as an option. They provide a much longer service life than a polyester filter. Fiberglass filter is required for temperatures greater than 149°C. Maximum fiberglass filter temperature is 370°C. Filters with other micron ratings are available upon request.

The high capacity fiberglass filter option, shown in the diagram below, provides a reservoir for applications with heavy particle loads that might block the inlet. The high capacity filter option is not available for 8 inch bodies.

The two-piece trap body and 304 stainless steel construction allow these traps to be easily cleaned. For proper sealing, apply a light coating of Krytox lube when cleaning or replacing the O-ring. Standard finish is beadblast. Electropolish finish, larger body sizes, ultra-high capacity and custom flange configurations available. Call for pricing.

### SPECIFICATIONS

**Material**  
 Trap Body: 304 stainless steel  
 Flanges: 304 stainless steel  
 Filter: polyester or fiberglass

**Vacuum range:**  $\geq 1 \times 10^{-8}$  Torr

**Temperature range:** -20°C to 150°C

**Options:** ISO body flanges, woven fiberglass or high capacity fiberglass filter, electropolish

### Angle Particulate Traps

| MODEL NUMBER    | BODY OD | FLANGES | PORT OD | A     | B    | C     | D    |
|-----------------|---------|---------|---------|-------|------|-------|------|
| FTPA-6-1502-NWB | 6       | NW-40B  | 1½      | 13.90 | 6.90 | 10.40 | 4.65 |
| FTPA-6-2002-NWB | 6       | NW-50B  | 2       | 13.90 | 6.90 | 10.15 | 4.65 |
| FTPA-8-1502-NWB | 8*      | NW-40B  | 1½      | 13.90 | 9.00 | 10.40 | 5.65 |
| FTPA-8-2002-NWB | 8*      | NW-50B  | 2       | 13.90 | 9.00 | 10.15 | 5.65 |
| FTPA-8-3002-ISO | 8*      | ISO-80  | 2       | 19.35 | 9.00 | 15.25 | 5.65 |
| FTPA-8-4002-ISO | 8*      | ISO-100 | 2       | 19.35 | 9.00 | 15.25 | 5.65 |

\* High capacity filter not available for 8 inch body

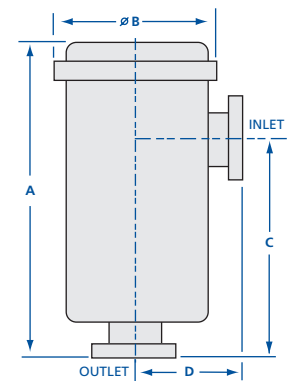

### Coaxial Particulate Traps

| MODEL NUMBER    | BODY OD | FLANGES | PORT OD | A     | B    |
|-----------------|---------|---------|---------|-------|------|
| FTPS-6-1502-NWB | 6       | NW-40B  | 1½      | 16.30 | 6.90 |
| FTPS-6-2002-NWB | 6       | NW-50B  | 2       | 16.30 | 6.90 |
| FTPS-8-1502-NWB | 8*      | NW-40B  | 1½      | 16.30 | 9.00 |
| FTPS-8-2002-NWB | 8*      | NW-50B  | 2       | 16.30 | 9.00 |
| FTPS-8-3002-ISO | 8*      | ISO-80  | 2       | 16.50 | 9.00 |
| FTPS-8-4002-ISO | 8*      | ISO-100 | 2       | 16.50 | 9.00 |

\* High capacity filter not available for 8 inch body

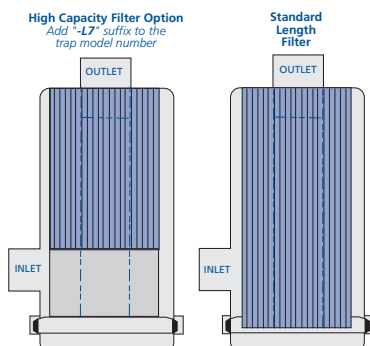
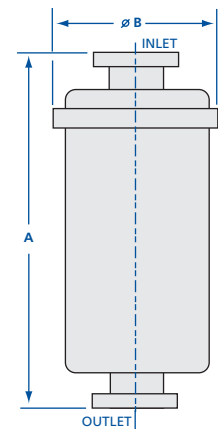

### Fiberglass Filter Option

The fiberglass filter option is appropriate for applications with temperatures up to 370°C. The high capacity fiberglass filter provides a reservoir for applications with heavy particle loads that might block the inlet. Add option suffix to the end of the trap model number.

| OPTION | FILTER TYPE   |
|--------|---------------|
| -F     | Fiberglass    |
| -L7    | High capacity |

# Foreline Traps

## LPCVD-TEOS Single & Multi-Stage Traps



### SPECIFICATIONS

#### Material

Trap Body: 304 stainless steel  
Flanges: 304 stainless steel  
Filter: Stainless steel gauze

**Vacuum range:**  $\geq 1 \times 10^{-8}$  Torr

**Temperature range:** -20°C to 150°C

Increase your system's throughput and extend preventative maintenance intervals by 2X or more with Nor-Cal Products' LPCVD/TEOS multistage foreline traps. The first stage is a stainless steel gauze filter which collects crystalline TEOS before it reaches downstream piping and isolation valves. The second stage is a 10 micron fiberglass filter which removes silicon dioxide which causes frequent PM's in throttling butterfly valves. The third and final stage is a reservoir which collects liquid TEOS without restricting foreline conductance. The two-piece trap body and 304 stainless steel construction allow these traps to be easily cleaned. Standard finish is beadblasted. Electropolish is available on request.



### One Stage LPCVD-TEOS Traps

Includes one stainless steel gauze filter

| MODEL NUMBER            | BODY OD | PORT CONFIGURATION | FLANGES | PORT ID | A     | B    | C     |
|-------------------------|---------|--------------------|---------|---------|-------|------|-------|
| <b>FTT1S-8-3002-ISO</b> | 8       | Coaxial            | ISO-80  | 3       | 16.84 | 9.00 | -     |
| <b>FTT1A-8-3002-ISO</b> | 8       | Angle              | ISO-80  | 3       | 15.09 | 5.75 | 12.06 |
| <b>FTT1S-8-4002-ISO</b> | 8       | Coaxial            | ISO-100 | 4       | 16.84 | 9.00 | -     |
| <b>FTT1A-8-4002-ISO</b> | 8       | Angle              | ISO-100 | 4       | 15.09 | 5.75 | 12.06 |

### Two Stage LPCVD-TEOS Traps

Includes one stainless steel gauze filter and one 10 micron fiberglass filter

| MODEL NUMBER            | BODY OD | PORT CONFIGURATION | FLANGES | PORT ID | A     | B    | C     |
|-------------------------|---------|--------------------|---------|---------|-------|------|-------|
| <b>FTT2S-8-3002-ISO</b> | 8       | Coaxial            | ISO-80  | 3       | 19.12 | 9.45 | -     |
| <b>FTT2A-8-3002-ISO</b> | 8       | Angle              | ISO-80  | 3       | 21.00 | 5.75 | 18.00 |
| <b>FTT2S-8-4002-ISO</b> | 8       | Coaxial            | ISO-100 | 4       | 19.12 | 9.45 | -     |
| <b>FTT2A-8-4002-ISO</b> | 8       | Angle              | ISO-100 | 4       | 21.00 | 5.75 | 18.00 |

### Three Stage LPCVD-TEOS Traps

Includes one stainless steel gauze filter, one 10 micron fiberglass filter, and a built-in liquid collection reservoir

| MODEL NUMBER            | BODY OD | PORT CONFIGURATION | FLANGES | PORT ID | A     | B    | C     |
|-------------------------|---------|--------------------|---------|---------|-------|------|-------|
| <b>FTT3S-8-3002-ISO</b> | 8       | Coaxial            | ISO-80  | 3       | 19.12 | 9.45 | -     |
| <b>FTT3A-8-3002-ISO</b> | 8       | Angle              | ISO-80  | 3       | 21.00 | 5.75 | 18.00 |
| <b>FTT3S-8-4002-ISO</b> | 8       | Coaxial            | ISO-100 | 4       | 19.12 | 9.45 | -     |
| <b>FTT3A-8-4002-ISO</b> | 8       | Angle              | ISO-100 | 4       | 21.00 | 5.75 | 18.00 |

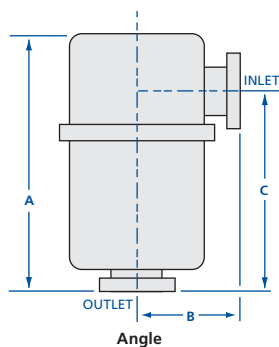
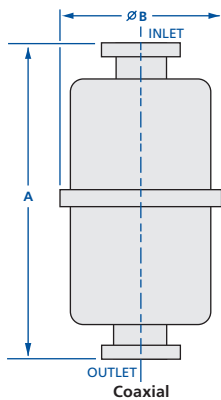

Replacement filters and other hardware are located on Page 166

# Foreline Traps

## Water Cooled Traps



Water cooled traps protect mechanical pumps and other downstream components from condensable process gasses and their by-products. They can extend or eliminate preventative maintenance intervals and pump overhauls. Nor-Cal's unique water cooled traps have up to three coils of corrosion resistant 316L stainless steel tubing to provide a large cold surface area. Internal baffles combined with the coils create a perilous path for the gas flow, maximizing resident time and increasing contact between the gas and the coils. Depending on the application, house water or refrigerated water can be used to achieve the required temperature to cause by-products to pass from gas to solid phase. (See chart on page 156) A 30 to 50 psi water supply is required. Anticipate a 1 gpm flow rate at 30 psi.

The two-piece trap body and 304 stainless steel construction allow these traps to be easily cleaned. Standard finish is beadblast. For proper sealing, apply a light coating of Krytox lube when cleaning or replacing the O-ring. Quick Disconnect Fittings immediately shut off water flow from both directions for single handed, no-spill removal of the trap for preventative maintenance or O-ring replacement. Add "-QD" to the trap model number and \$200.00 to price. Electropolish finish, larger body sizes and CF, EVAC or ASA flanges are also available.



### SPECIFICATIONS

**Material**  
 Trap Body: 304 stainless steel  
 Flanges: 304 stainless steel  
 Water Coils: 316L stainless steel

**Vacuum range:**  $\geq 1 \times 10^{-8}$  Torr

**Temperature range:** -20°C to 150°C

**Options:** ISO body flanges and quick disconnect fittings. See page 157

## Coaxial Water Cooled Traps

| MODEL NUMBER      | DIAGRAM | BODY OD | FLANGE TYPE    | PORT OD | A     | B    |
|-------------------|---------|---------|----------------|---------|-------|------|
| FTWS-4.5-1502-NWB | A       | 4 1/2   | NW-40B         | 1 1/2   | 9.75  | 5.28 |
| FTWS-4.5-2002-NWB | A       | 4 1/2   | NW-50B         | 2       | 9.75  | 5.28 |
| FTWS-6-1502-NWB   | B       | 6       | NW-40B         | 1 1/2   | 10.30 | 6.90 |
| FTWS-6-2002-NWB   | B       | 6       | NW-50B         | 2       | 10.30 | 6.90 |
| FTWS-6-2502-ISO   | B       | 6       | ISO-63-250-OF  | 2 1/2   | 10.50 | 6.90 |
| FTWS-6-3002-ISO   | B       | 6       | ISO-80-300-OF  | 3       | 10.50 | 6.90 |
| FTWS-8-2002-NWB   | B       | 8       | NW-50B         | 2       | 13.30 | 9.00 |
| FTWS-8-2502-ISO   | B       | 8       | ISO-63-250-OF  | 2 1/2   | 13.50 | 9.00 |
| FTWS-8-3002-ISO   | B       | 8       | ISO-80-300-OF  | 3       | 13.50 | 9.00 |
| FTWS-8-4002-ISO   | B       | 8       | ISO-100-400-OF | 4       | 13.50 | 9.00 |

\*NOTE: ISO body flange option not available for 4 1/2 inch bodies

## Angle Water Cooled Traps

| MODEL NUMBER      | DIAGRAM | BODY OD | FLANGES        | PORT OD | A     | B    | C    | D    |
|-------------------|---------|---------|----------------|---------|-------|------|------|------|
| FTWA-4.5-1502-NWB | C       | 4 1/2   | NW-40B         | 1 1/2   | 7.55  | 5.28 | 3.90 | 6.05 |
| FTWA-4.5-2002-NWB | C       | 4 1/2   | NW-50B         | 2       | 7.55  | 5.28 | 3.90 | 6.05 |
| FTWA-6-1502-NWB   | D       | 6       | NW-40B         | 1 1/2   | 8.65  | 6.90 | 4.65 | 5.40 |
| FTWA-6-2002-NWB   | D       | 6       | NW-50B         | 2       | 8.65  | 6.90 | 4.65 | 5.40 |
| FTWA-6-2502-ISO   | D       | 6       | ISO-63-250-OF  | 2 1/2   | 8.75  | 6.90 | 4.75 | 5.50 |
| FTWA-6-3002-ISO   | D       | 6       | ISO-80-300-OF  | 3       | 8.75  | 6.90 | 4.75 | 5.50 |
| FTWA-8-2002-NWB   | D       | 8       | NW-50B         | 2       | 11.65 | 9.00 | 5.65 | 6.77 |
| FTWA-8-2502-ISO   | D       | 8       | ISO-63-250-OF  | 2 1/2   | 11.75 | 9.00 | 5.75 | 7.87 |
| FTWA-8-3002-ISO   | D       | 8       | ISO-80-300-OF  | 3       | 11.75 | 9.00 | 5.75 | 6.87 |
| FTWA-8-4002-ISO   | D       | 8       | ISO-100-400-OF | 4       | 11.75 | 9.00 | 5.75 | 6.87 |

\*NOTE: ISO body flange option not available for 4 1/2 inch bodies

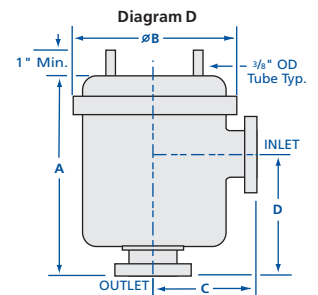
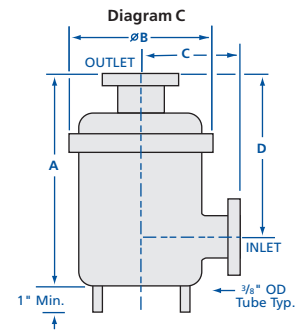
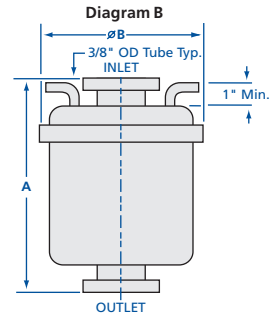
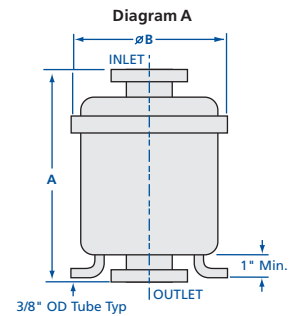

### Quick Disconnect Option

Add option suffix to trap model number.

| OPTION | FITS TRAP TYPE |
|--------|----------------|
| -QD    | Water cooled   |

Immediately shuts off water flow from both directions for single-handed, no-spill removal of a water cooled trap from the system for preventative maintenance or O-ring replacement.

**Quick disconnect fittings & mounting hardware are located on Page 166**

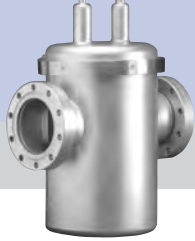

# Foreline Traps

## Liquid Nitrogen Traps

### SPECIFICATIONS

#### Material

Trap Body: 304 stainless steel  
Flanges: 304 stainless steel

**Vacuum range:**  $\geq 1 \times 10^{-8}$  Torr

**Temperature range:** -20°C to 150°C

**Options:** ISO body flanges. See page 141

Nor-Cal's liquid nitrogen traps remove condensable gasses before they enter the mechanical pump and contaminate the oil. They also prevent mechanical pump oil vapors from contaminating the vacuum chamber. These traps actually act as a pump producing lower base pressures and faster pump down. Dual-tube traps can be attached to an automatic fill device, eliminating the necessity of manually refilling the reservoir with liquid nitrogen.

The two-piece trap body and 304 stainless steel construction allow these traps to be easily cleaned without disassembling the system. For proper sealing, apply a light coating of Krytox lube when cleaning or replacing the O-ring. Coaxial port configurations, ISO, CF, EVAC or ASA flanges, electropolish finish and drain fittings are available.

### Refill Time Table for Single Tube LN<sup>2</sup> Traps

| TRAP DIAMETER | HOURS |
|---------------|-------|
| 4 inch        | 5     |
| 6 inch        | 8     |
| 8 inch        | 12    |

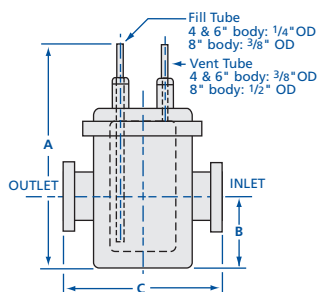
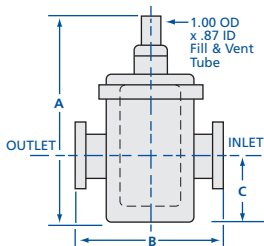
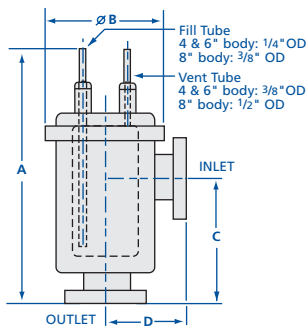
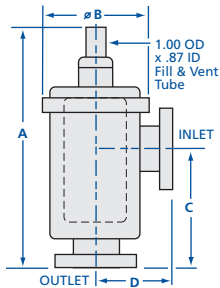

### Angle Liquid Nitrogen Traps

| MODEL NUMBER           | BODY OD | FLANGES | PORT OD | A     | B    | C    | D    | LN <sub>2</sub> RESERVOIR |
|------------------------|---------|---------|---------|-------|------|------|------|---------------------------|
| <b>FTNA-4-0752-NWB</b> | 4       | NW-16B  | 3/4     | 13.15 | 4.80 | 7.18 | 3.65 | 0.75 Liter                |
| <b>FTNA-4-1002-NWB</b> | 4       | NW-25B  | 1       | 13.15 | 4.80 | 7.06 | 3.65 | 0.75 Liter                |
| <b>FTNA-4-1502-NWB</b> | 4       | NW-40B  | 1 1/2   | 13.15 | 4.80 | 6.80 | 3.65 | 0.75 Liter                |
| <b>FTNA-6-1502-NWB</b> | 6       | NW-40B  | 1 1/2   | 15.85 | 6.90 | 8.40 | 4.65 | 1.60 Liter                |
| <b>FTNA-6-2002-NWB</b> | 6       | NW-50B  | 2       | 15.85 | 6.90 | 8.15 | 4.65 | 1.60 Liter                |
| <b>FTNA-8-1502-NWB</b> | 8       | NW-40B  | 1 1/2   | 16.90 | 9.00 | 9.15 | 5.65 | 4.00 Liter                |
| <b>FTNA-8-2002-NWB</b> | 8       | NW-50B  | 2       | 16.90 | 9.00 | 8.90 | 5.65 | 4.00 Liter                |

### Angle Dual-Tube Liquid Nitrogen Traps

| MODEL NUMBER           | BODY OD | FLANGES | PORT OD | A     | B    | C    | D    | LN <sub>2</sub> RESERVOIR |
|------------------------|---------|---------|---------|-------|------|------|------|---------------------------|
| <b>NTDA-4-0752-NWB</b> | 4       | NW-16B  | 3/4     | 13.15 | 4.80 | 7.18 | 3.65 | 0.75 Liter                |
| <b>NTDA-4-1002-NWB</b> | 4       | NW-25B  | 1       | 13.15 | 4.80 | 7.06 | 3.65 | 0.75 Liter                |
| <b>NTDA-4-1502-NWB</b> | 4       | NW-40B  | 1 1/2   | 13.15 | 4.80 | 6.80 | 3.65 | 0.75 Liter                |
| <b>NTDA-6-1502-NWB</b> | 6       | NW-40B  | 1 1/2   | 15.85 | 6.90 | 8.40 | 4.65 | 1.60 Liter                |
| <b>NTDA-6-2002-NWB</b> | 6       | NW-50B  | 2       | 15.85 | 6.90 | 8.15 | 4.65 | 1.60 Liter                |
| <b>NTDA-8-1502-NWB</b> | 8       | NW-40B  | 1 1/2   | 16.90 | 9.00 | 9.15 | 5.65 | 4.00 Liter                |
| <b>NTDA-8-2002-NWB</b> | 8       | NW-50B  | 2       | 16.90 | 9.00 | 8.90 | 5.65 | 4.00 Liter                |

### In-Line Liquid Nitrogen Traps

| MODEL NUMBER          | BODY OD | FLANGES | PORT OD | A     | B     | C    | LN <sub>2</sub> RESERVOIR |
|-----------------------|---------|---------|---------|-------|-------|------|---------------------------|
| <b>FTN-4-0752-NWB</b> | 4       | NW-16B  | 3/4     | 11.50 | 7.30  | 3.70 | 0.75 Liter                |
| <b>FTN-4-1002-NWB</b> | 4       | NW-25B  | 1       | 11.50 | 7.30  | 3.70 | 0.75 Liter                |
| <b>FTN-4-1502-NWB</b> | 4       | NW-40B  | 1 1/2   | 11.50 | 7.30  | 3.70 | 0.75 Liter                |
| <b>FTN-6-1502-NWB</b> | 6       | NW-40B  | 1 1/2   | 14.20 | 9.30  | 4.50 | 1.60 Liter                |
| <b>FTN-6-2002-NWB</b> | 6       | NW-50B  | 2       | 14.20 | 9.30  | 4.50 | 1.60 Liter                |
| <b>FTN-8-1502-NWB</b> | 8       | NW-40B  | 1 1/2   | 15.25 | 11.30 | 5.00 | 4.00 Liter                |
| <b>FTN-8-2002-NWB</b> | 8       | NW-50B  | 2       | 15.25 | 11.30 | 5.00 | 4.00 Liter                |

### In-Line Dual-Tube Liquid Nitrogen Traps

| MODEL NUMBER          | BODY OD | FLANGES | PORT OD | A     | B    | C     | LN <sub>2</sub> RESERVOIR |
|-----------------------|---------|---------|---------|-------|------|-------|---------------------------|
| <b>NTD-4-0752-NWB</b> | 4       | NW-16B  | 3/4     | 11.50 | 3.70 | 7.30  | 0.75 Liter                |
| <b>NTD-4-1002-NWB</b> | 4       | NW-25B  | 1       | 11.50 | 3.70 | 7.30  | 0.75 Liter                |
| <b>NTD-4-1502-NWB</b> | 4       | NW-40B  | 1 1/2   | 11.50 | 3.70 | 7.30  | 0.75 Liter                |
| <b>NTD-6-1502-NWB</b> | 6       | NW-40B  | 1 1/2   | 14.20 | 4.50 | 9.30  | 1.60 Liter                |
| <b>NTD-6-2002-NWB</b> | 6       | NW-50B  | 2       | 14.20 | 4.50 | 9.30  | 1.60 Liter                |
| <b>NTD-8-1502-NWB</b> | 8       | NW-40B  | 1 1/2   | 15.25 | 5.00 | 11.30 | 4.00 Liter                |
| <b>NTD-8-2002-NWB</b> | 8       | NW-50B  | 2       | 15.25 | 5.00 | 11.30 | 4.00 Liter                |



During rotary vane pump operation, oil mist escapes from the exhaust port; mainly when pumping between atmospheric pressure and 1 mbar. Safe operation of a rotary vane pump requires an Oil Mist Eliminator (OME) to be mounted above the pump's exhaust port. The oil mist is present in exhaust gases with a high level of separation. These mists present a potential environmental and health hazard as well as creating an oily build-up on everything in the pump's proximity. Misting increases as exhaust pressure increases.



### SPECIFICATIONS

#### Material

Trap Body: 304 stainless steel, aluminum or Polyamide  
Filter: Epoxy/glass microfiber, Polypropylene

The OME's filtration system contains the mist and returns it to the pump body. The OME's internal over-pressure valve prevents vapor explosions due to exceeding the maximum permissible exhaust pressure. Oil mist eliminators do not trap gas.

**Caution:** Vent all processes properly. Oil mist eliminators are not recommended for applications with high oxygen, silane, or condensable vapor content. Seal kits, auto drain kits, and other accessories are available. Call for pricing.

## Oil Mist Eliminators

| MODEL NUMBER | DIAGRAM | PROCESS USAGE   | BODY MATERIAL   | FLANGE TYPE |
|--------------|---------|---|-----------------|-------------|
| FTOME-25-S   | A       | General, non-corrosive  | Polyamide       | NW-25       |
| FTOME-25-HP  | B       | General, non-corrosive. For frequent cycling or high pressure operation | Aluminum        | NW-25       |
| FTOME-40-S   | C       | General, non-corrosive  | Aluminum        | NW-40       |
| FTOME-40-C2  | D       | Fluorinated, corrosive  | Stainless Steel | NW-40       |

## Replacement Filters

| MODEL NUMBER  | USE WITH    | FILTER MATERIAL        | QUANTITY |
|---------------|-------------|------------------------|----------|
| FTOME-25-S-F  | FTOME-25-S  | Epoxy/glass microfiber | 1        |
| FTOME-25-HP-F | FTOME-25-HP | Epoxy/glass microfiber | 1        |
| FTOME-40-S-F  | FTOME-40-S  | Epoxy/glass microfiber | 1        |
| FTOME-40-C2-F | FTOME-40-C2 | Polypropylene          | 1        |

Diagram A

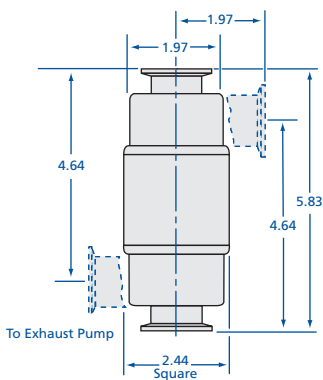

Diagram B

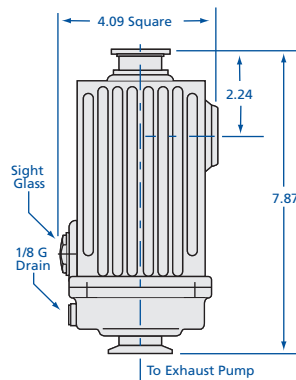

Diagram C

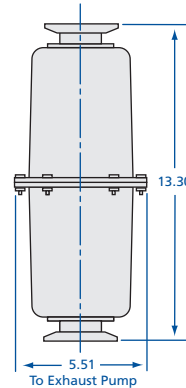
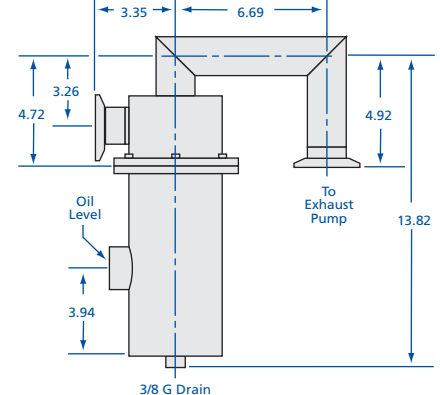
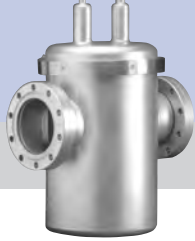

Diagram D



# Foreline Traps

## Filters, Hardware & Accessories



Metal sieve trap filters

### Metal Sieve Trap Replacement Filters

| MODEL NUMBER | BODY OD | DESCRIPTION           |
|--------------|---------|-----------------------|
| FT-2-SS      | 2       | Stainless steel gauze |
| FT-2-CS      | 2       | Copper gauze          |
| FT-4-SS      | 4       | Stainless steel gauze |
| FT-4-CS      | 4       | Copper gauze          |
| FT-6-SS      | 6       | Stainless steel gauze |
| FT-6-CS      | 6       | Copper gauze          |
| FT-8-SS      | 8       | Stainless steel gauze |
| FT-8-CS      | 8       | Copper gauze          |



Trap mounting bracket

### Body Clamps

Body clamps for use with all trap types

| MODEL NUMBER | BODY OD            |
|--------------|--------------------|
| NW-50-CP     | 2                  |
| FT-4-CP      | 4                  |
| FT-4.5-CP    | 4½                 |
| FT-6-CP      | 6                  |
| 50248        | 8 above S/N 292800 |
| FT-CP-B      | T-bolt kit*        |

\* T-bolt kits include replacement bolts and nuts for all size V-band clamps and brackets.



Particulate trap filters

### Particulate Trap Replacement Filters

| MODEL NUMBER | BODY OD | FILTER LENGTH | DESCRIPTION                        |
|--------------|---------|---------------|------------------------------------|
| FT-6-PP      | 6 or 8  | 11½           | Polyester felt, 10 micron          |
| FT-6-PF      | 6 or 8  | 11½           | Woven fiberglass, 10 micron        |
| FT-6-PF-L7   | 6       | 7½            | Woven fiberglass filter, 10 micron |
| FT-8-PR      | 8       | 11½           | Polypropylene filter, 10 micron    |

### LPCVD-TEOS Trap Replacement Filters

| MODEL NUMBER | BODY OD | FILTER MATERIAL       | FITS TRAPS    |
|--------------|---------|-----------------------|---------------|
| FT-8-SS      | 8       | Stainless steel gauze | FTT1          |
| FT-8-SS-5    | 8       | Stainless steel gauze | FTT2 and FTT3 |
| FT-8-PF-5    | 8       | Woven fiberglass      | FTT2 and FTT3 |

### Body O-rings

For use with all foreline trap types.

| MODEL NUMBER | BODY OD |
|--------------|---------|
| NW-50-OR-V   | 2       |
| FT-4-OR      | 4       |
| FT-4.5-OR    | 4½      |
| FT-6-OR      | 6       |
| FT-8-OR      | 8       |



Molecular sieve trap heaters

### Molecular Sieve Trap Replacement Heaters

| MODEL NUMBER | BODY OD | DESCRIPTION         |
|--------------|---------|---------------------|
| FT-4-HR      | 4       | Rated at 120V, 125W |
| FT-4-HR-240V | 4       | Rated at 240V, 125W |
| FT-6-HR      | 6       | Rated at 120V, 230W |
| FT-6-HR-240V | 6       | Rated at 240V, 125W |
| FT-8-HR      | 8       | Rated at 120V, 350W |
| FT-8-HR-240V | 8       | Rated at 240V, 350W |

### Mounting Brackets

For mounting all 6 inch trap types.

| MODEL NUMBER | BODY OD |
|--------------|---------|
| FT-6-MB      | 6       |



Molecular sieve trap charge

### Molecular Sieve Trap Replacement Charges

| MODEL NUMBER | BODY OD | DESCRIPTION                                       |
|--------------|---------|---|
| FT-4-MS      | 4       | 1 lb. Zeolite charge, 4 inch trap requires ¾ lb.  |
| FT-6-MS      | 6       | 2 lb. Zeolite charge, 6 inch trap requires 1½ lb. |
| FT-8-MS      | 8       | 5 lb. Zeolite charge, 8 inch trap requires 4¾ lb. |

### Water Cooled Trap Fittings



| MODEL NUMBER | BODY OD | DESCRIPTION                                       |
|--------------|---------|---|
| FTW-QD       | All     | Quick disconnect fittings kit (DESO)              |
| FTW-4.5-OR   | 4½      | Internal Viton O-ring used in this body size only |