

Isolation Valves

Section Three



3.1	General Information	2
3.2	N-Series Valves	4
3.3	Poppet Valves	6
3.4	Ball Valves	18
3.5	Genesis Valves & Fittings	20
3.6	Manual Butterfly Valves	27
3.7	Pendulum Valves	28
3.8	Linear Gate Valves	29
3.9	Bellowless Poppet Valves & Leak Valves	32
3.10	Isolation Valve Heaters	33
3.11	Bakeable All Metal Valves	34

Nor-Cal Products, Inc.
 1967 So. Oregon
 Yreka, CA 96097 USA

Tel: **800-824-4166**
 or 530-842-4457
 Main Fax: 530-842-9130
 Sales Fax: 530-841-9189
www.n-c.com





Since 1962, Nor-Cal Products has been improving our valve designs and expanding our product line in order to offer valves for almost every vacuum application. Our valves provide outstanding performance in the most demanding applications such as semiconductor and compound semiconductor processing.

Valve Applications

PROCESS APPLICATION	VALVE TYPE	UNIQUE FEATURES	SIZES (NOMINAL ID)	SEAT SEAL	TEMPERATURE RANGE	PRESSURE RANGE	ACTUATION	CYCLES ⁽¹⁾
HIGH-VACUUM ROUGHING	N-Series	Compact. High Cycle.	3/4 to 2	Viton	-20° to 150°C	1000 to 10 ⁻⁹ Torr	Pneumatic	3,000,000
	Poppet	Large stroke	3/8 to 4	Viton	-20° to 150°C	1000 to 10 ⁻⁹ Torr	Manual or Pneumatic	250,000
	Genesis	Small footprint. Low profile	3/4 to 4	Viton	-20° to 150°C	1000 to 10 ⁻⁹ Torr	Pneumatic	1,000,000
	Bellowless Poppet	O-ring sealed shaft	3/8 to 2	Viton	-20° to 150°C	1000 to 10 ⁻⁹ Torr	Pneumatic	250,000
	Butterfly	Low profile. 1/4 swing	3/4 to 1 1/2	Viton	-20° to 150°C	1000 to 10 ⁻⁹ Torr	Manual	30,000
UHV ROUGHING	All-metal	All-metal seals	3/4 & 1 1/2	Copper	-250° to 400°C	1000 to 10 ⁻¹¹ Torr	Manual	10,000 ⁽²⁾
HV, UHV PUMP ISOLATION	Gate	Highest conductance	5/8 to 12	Viton	-20° to 150°C	1000 to 10 ⁻¹⁰ Torr	Manual or Pneumatic	100,000 ⁽³⁾
HIGH-VACUUM PUMP ISOLATION	Pendulum	Low particle generation. Low vibration	6 to 16	Viton	-20° to 150°C	1000 to 10 ⁻⁹ Torr	Pneumatic	200,000
PUMP EXHAUST	Ball	1/4 swing open/close	3/4 to 2	Teflon	20° to 150°C	1000 to 10 ⁻⁴ Torr	Manual	20,000
GAS INTRODUCTION	Leak	Variable leak	N/A	Copper	-250° to 450°C	1000 to ≥1x 10 ⁻¹¹ Torr	Manual	300 ⁽²⁾

(1) MTBF (2) Cycle life is reduced with high temperature bakeouts (3) Optional Million Cycle Valve is available.

Poppet Valves

Our poppet valves are fully opening for high conductance and to prevent bellows contamination while the valve is in the open position, reducing particle contamination when the valve is cycled. Our bodies are die-formed from 304 stainless steel to eliminate sharp inside corners and improve conductance. The valves are electropolished for lower outgassing and better corrosion resistance. The welded bellows are made from AM-350 stainless steel to provide excellent corrosion resistance and flexibility. They are designed with additional segments to provide extended life.

Ball Valves

Ball valves are a low cost, manually or pneumatically operated, straight through isolation device. Their simple, robust design provides high reliability in "dirty" applications. They are commonly used on MOCVD and CVD equipment downstream from the chamber or vacuum pump to isolate traps or abatement tools. A stainless steel body and Teflon seat make these valves ideal for corrosive environments. Other applications include vacuum and other facilities requirements.

Genesis Valves

The Genesis modular vacuum valve system provides semiconductor equipment designers with unlimited possibilities for downstream vacuum subassemblies. Nippleless valve bodies and block fittings can be assembled by two attachment methods using universal ISO-KF centering ring/O-ring hardware, providing maximum flexibility and the smallest footprint possible. Additionally these valves feature million cycle reliability, integrated low-cost soft start circuit and modular heaters.

Linear Gate Valves

Our linear gate valves have an ultra-slim profile, which makes them perfect for applications where space is limited, and their smaller volume results in lower outgassing and faster pump-down. Larger sizes have a unique feature in the actuator, which dampens the vibration, which can arise when the gate is opened. This makes these valves ideal for semiconductor and other vibration sensitive processes.

All-Metal Valves

Nor-Cal's bakeable all-metal seal angle valves are intended for use in UHV or cryogenic applications where temperature extremes preclude the use of our elastomer seal valves. Approved for use in beamline facilities, these valves have a temperature operating range from -250°C to 400°C.





New Products

N-Series Poppet Valves

The new N-Series poppet valves are an innovative, compact design with an MTBF of 3 million cycles. A bellows-sealed stem and electropolished stainless steel body provides long life even in the most demanding applications. Standard pneumatic actuation is normally closed. N-series valves are available in right angle or angle-in-line body styles with tube ends, NW flanges and CF rotatable flanges. Optional air solenoids are available in multiple voltages and can be ordered factory installed or as separate kits for easy field installation.



Leak Valves

Leak valves are used for controlling gas introduction into high and ultra-high vacuum systems. They utilize an optically flat sapphire poppet and a metal seal seat, allowing bakeout temperatures to 450°C.

Manual Butterfly Valves

These Viton O-ring sealed valves provide a low-cost alternative to bellows sealed gate valves. Quarter-turn actuation, small footprint and the shortest possible gas path make manual butterfly valves the preferred choice for many applications.



Machined Ball Valves

Our new ball valves are a low cost, manually or pneumatically operated, straight through isolation device. Their simple, robust design provides high reliability in "dirty" applications. They are commonly used on MOCVD and CVD equipment downstream from the chamber or vacuum pump to isolate traps or abatement tools. A stainless steel body and Teflon seat make these valves ideal for corrosive environments. A quarter turn of the handle quickly switches the valve from open to close. They are available with NW-16 through NW-50 flanges as standards. Heater jackets are available to reduce process by-product accumulation.



Custom Valves

Nor-Cal frequently provides custom and modified standard isolation valves to meet our customer's specific requirements. Single or multiple valves can be integrated with manifolds, chambers and other components. Many special features can be specified by adding options. See page 99.

Standard Options

- Normally open pneumatic actuation
- Microswitch position indication
- Special O-rings
- Various air solenoid voltages
- Fitting options for bypass lines
- Heater jackets, insulators and controllers

Custom Features

- Special port lengths and configurations for drop-in compatibility with other manufacturer's valves
- Custom flange configurations
- Special position indicators
- Pump out ports
- Custom finishes
- Gate shields for linear gate valve O-rings



Spring-to-close pneumatic actuator with gate shield

Custom fitting option



Custom valve manifold

Isolation Valves

N-Series Valves



SPECIFICATIONS

Port OD's: 3/4, 1 and 1 1/2 inches

Materials

Body: Electropolished 304 stainless steel

Bellows: Welded AM-350 stainless steel

Bonnet seal: Viton

Poppet seal: Viton

Other O-ring compounds available

Actuation: Spring / Pneumatic

Air-to-open, spring-to-close

Leak Rates: 1×10^{-9} std. cc/sec He to atmosphere, 1×10^{-9} std. cc/sec He across the seat.

Operating Temperature: 150°C Max.

Supply Pressure: 60-100 psig

Differential pressure: Maximum 20 psid across valve seat

Maximum temperature with Viton seals: 150°C Max

Vacuum Range: 1000 to 1×10^{-9} Torr

Options: Solenoids, magnetic, mechanical and optical sensors, Soft Start. Heater jackets and controllers available for all valves.



The new N-Series poppet valves are an innovative, compact design with an MTBF of 3 million cycles. A bellows-sealed stem and electropolished stainless steel body provides long life even in the most demanding applications. Standard pneumatic actuation is normally closed (Air-to-Open / Spring-to-Close). N-series valves are available in right angle or angle-in-line body styles with tube ends, NW flanges and CF rotatable flanges. Optional air solenoids are available in

multiple voltages and can be ordered factory installed or as separate kits for easy field installation.

Mounting slots for optional position indicators are incorporated into the actuator body resulting in a reduction in overall size and elimination of the risk of physical damage to the sensors. Sensors are easily installed without adjustment and are available in three types. Mechanical, Optical or Reed switch sensors indicate both the

open & closed valve positions. It is possible for each valve to have two sensors installed for redundancy. Position indicators can be ordered factory installed or as separate kits for easy field installation.

One rebuild kit fits the four valve sizes from NW-16 through NW-50 to reduce maintenance inventory costs. Viton O-ring seals are standard, however the valve is designed to accept alternate seal compounds to satisfy your application requirements.

N-Series Options

Please use the following part numbering tree to add the appropriate options to a standard N-Series valve model number. See tables below for option codes.

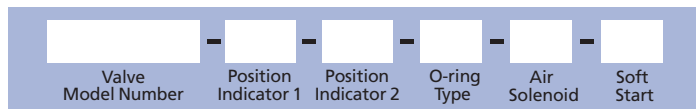

Example: NAP-150-NW-M-M-K79-S11-SS

Right angle N-Series valve with 1.5 inch bore, NW-40 flanges, redundant mechanical position indicators, Kalrez 4079 O-rings, 120VAC air solenoid and soft start option.

O-ring Material Options

SEAL MATERIAL	CODE
Viton	Default (no code)
Kalrez 4079	-K79
Kalrez 8085	-K85
Kalrez 8575	-K75
Kalrez 9100	-K91
Chemraz E38	-C38
Dupra 192	-D19
Perlast G74P	-PP7

Air Solenoid Option

DESCRIPTION	CODE	KIT
120VAC, 50/60 Hz	-S11	N-S11-K
24VDC	-S21	N-S21-K
240VAC, 50/60 Hz	-S31	N-S31-K
24VAC, 50/60 Hz	-S41	N-S41-K

Position Indicator Option

DESCRIPTION	CODE
Mechanical - main valve open & closed	-M
Optical - main valve open & closed	-O
Reed Switch, magnetically actuated -main valve open & closed	-R

* **Note:** It is possible for each valve to have two sensors for redundancy

All dimensions are in inches (mm) & weights are in pounds (kg), unless otherwise noted.

Soft-Start Option

DESCRIPTION	CODE
Soft-Start	-SS



Pneumatic N-Series Angle Valve

MODEL NUMBER	PORT OD	DESCRIPTION	A	B	C
NAP-075	0.75	No Flanges	1.42 (36)	3.95 (100)	4.90 (124)
NAP-075-NW	0.75	NW-16	1.57 (40)	4.10 (104)	5.05 (128)
NAP-075-CF	0.75	CF-133, Rotatable	1.91 (49)	4.73 (120)	5.68 (144)
NAP-100	1.0	No Flanges	1.82 (46)	4.35 (110)	5.30 (134)
NAP-100-NW	1.0	NW-25	1.97 (50)	4.50 (114)	5.45 (138)
NAP-100-CF	1.0	CF-212, Rotatable	2.28 (58)	4.81 (122)	5.76 (146)
NAP-150	1.5	No Flanges	2.41 (61)	4.94 (125)	5.89 (149)
NAP-150-NW	1.5	NW-40	2.56 (65)	5.09 (129)	6.04 (153)
NAP-150-CF	1.5	CF-275, Rotatable	2.62 (67)	5.15 (131)	6.09 (155)
NAP-200	1.5	No Flanges	2.61 (66)	5.14 (131)	6.09 (155)
NAP-200-NW	1.5	NW-50	2.76 (70)	5.29 (134)	6.24 (158)
NAP-200-CF	1.5	CF-338, Rotatable	2.84 (72)	5.37 (136)	6.32 (160)

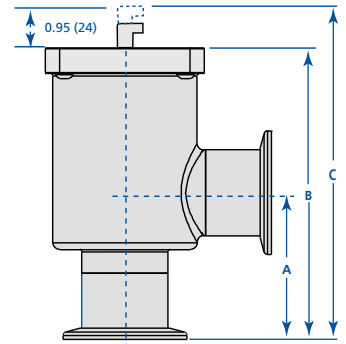
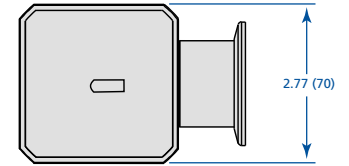

Pneumatic N-Series Angle In-Line Valve

MODEL NUMBER	PORT OD	DESCRIPTION	A	B
NAIP-075	0.75	No Flanges	3.64 (92)	4.60 (117)
NAIP-075-NW	0.75	NW-16	3.94 (100)	4.60 (117)
NAIP-075-CF	0.75	CF-133, Rotatable	4.20 (107)	4.60 (117)
NAIP-100	1.0	No Flanges	3.64 (92)	4.00 (102)
NAIP-100-NW	1.0	NW-25	3.94 (100)	4.00 (102)
NAIP-100-CF	1.0	CF-212, Rotatable	4.75 (121)	4.00 (102)
NAIP-150	1.5	No Flanges	4.82 (122)	4.37 (111)
NAIP-150-NW	1.5	NW-40	5.12 (130)	4.37 (111)
NAIP-150-CF	1.5	CF-275, Rotatable	5.24 (133)	4.37 (111)
NAIP-200	1.5	No Flanges	5.21 (132)	4.37 (111)
NAIP-200-NW	1.5	NW-50	5.51 (140)	4.37 (111)
NAIP-200-CF	1.5	CF-338, Rotatable	5.66 (144)	4.37 (111)

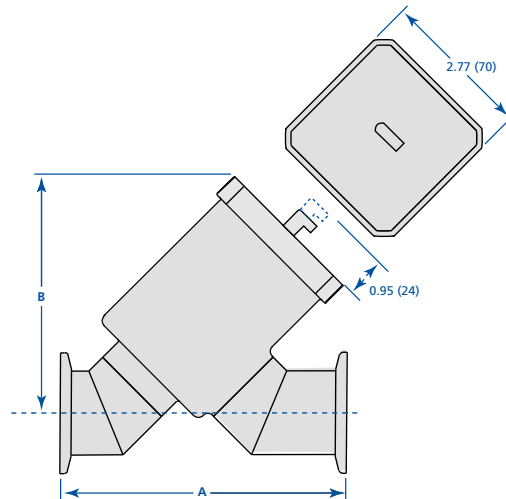

N-Series Seal Kit

MODEL NUMBER	DESCRIPTION
NA-075-95	Seal kit for 0.75 through 2 inch sizes, Viton. Includes (1) poppet and (1) bonnet O-ring.

N-Series Rebuild Kit

MODEL NUMBER	DESCRIPTION
NA-075-99	Valve rebuild kit for 0.75 through 2 inch sizes. Includes valve actuator/bellows assembly.

Note: Seals are not included. Recommend use of the NA-075-95 Seal Kit.

All dimensions are in inches (mm) & weights are in pounds (kg), unless otherwise noted.



Isolation Valves

Poppet Valve General Information

SPECIFICATIONS

Nominal port ODs: 3/8 to 4 inch

Body: Electropolished 304 stainless steel

Bellows: Welded AM-350 stainless steel

Bonnet seal: Viton or Copper

Poppet seal: Viton

Other O-ring compounds available

Flanges: CF, NW, ISO, ASA or EVAC

Maximum temperature with Viton seals

See bakeability chart this page

Sustained: $\leq 150^{\circ}\text{C}$

Intermittent: $\leq 204^{\circ}\text{C}$

Helium leak tested: 10^{-9} std. cc./sec. or less

Vacuum range

Viton bonnet seal: $\geq 1 \times 10^{-9}$ Torr - High Vacuum

Copper bonnet seal: $\geq 1 \times 10^{-10}$ Torr - UHV

Manual actuation: Bronze nuts/ACME threads

Pneumatic actuation: Normally closed

Operating Pressure: 60 to 80 psig

3/4 to 2 inch ODs: Air-to-open/spring-to-close

2 1/2 to 4 inch ODs: Air-to-open/air-to-close

Differential pressure: Max. 20 psia across valve seat (*External differential pressures greater than 5 psi on the bellows may result in premature bellows failure*)

Options: See facing page.

Thermal: Heater jackets and controllers available for all valves. *Call for details*

Construction

Bodies are die-formed from 304 stainless steel to eliminate sharp inside corners and improve conductance. The valves are electropolished for faster pumpdown, lower outgassing and better corrosion resistance. The welded bellows are made from AM-350 stainless steel to provide corrosion resistance and excellent flexibility. The bellows fully retract from the side port when the valve is open, eliminating buildup of by-products on the bellows and subsequent particle generation during operation. They are designed with additional segments to provide extended life. Nor-Cal valves can be operated in any position and actuators can be removed quickly for routine inspection without disassembling the system.

Models

Our poppet valves are available in most port configurations with CF, NW, ISO, EVAC or ASA flanges. Valves through 3 inch OD's are available with manual or pneumatic actuators and Viton or copper bonnet seals. Valves over three inches are available with pneumatic actuators only. Custom port lengths, flange configurations and bellows valves are also available.

Vacuum Range

Poppet seals have helium leak rates of 10^{-9} std. cc./sec. or less. Viton bonnet sealed valves can be used in the 10^{-9} Torr range, while copper bonnet seal valves are suited for use in the 10^{-10} range.

Copper Bonnet Seal

Copper bonnet seal poppet valves with CF flanges provide metal seals between the inside of the valve and the atmosphere. They are available in all standard sizes and port configurations.

Valve Actuation

Manually operated valves utilize Acme threads and a self-lubricating bronze nut for fewer turns and smooth, trouble-free operation. Pneumatic valves are normally air-to-open, spring-to-close in port ODs through 2 inches for immediate closure in case of electrical or air failure. Larger valves are normally air-to-open, air-to-close. This actuation option is available on all valves. Most sizes are available with air-to open, air-to-close with spring assist as an option. Operating air pressure for all pneumatic valves is 60 to 80 psig.

Thermal Products

All Nor-Cal poppet valves and gate valves can be provided with silicone foam or fiberglass insulated heater jackets to reduce resident time of corrosives or particle buildup in semiconductor applications. These jackets are available with PID controllers or thermostats with high temperature shutoffs. Jacket and control specifications can be tailored to meet your specific needs. Call for price and model number. Refer to Section 11, Thermal Products, for more information.



ESVP
cutaway
view



Bakeability

The valve's bakeout temperature should not exceed that of the elastomer that is used in it. See chart below. Standard Viton sealed valves are bakeable to 150°C sustained and 204°C for intermittent periods. However, the Viton O-rings begin to take a set at 150°C . High temperature Kalrez O-rings are available as an option and allow these valves to be baked to 220°C for intermittent periods and 170°C for extended periods.

BONNET/POPPET SEAL	APPLICATION	PNEUMATIC VALVES		MANUAL VALVES	
		OPEN	CLOSED	OPEN	CLOSED
Viton	General purpose	150°C	120°C	150°C	100°C
Kalrez 4079	High temperature	280°C	220°C	280°C	150°C
Kalrez 2037	Chemical resistant	218°C	218°C	218°C	218°C
Chemraz	Chemical resistant	210°C	210°C	210°C	210°C
Silicone	High temperature	232°C	232°C	232°C	232°C

Poppet Valve Conductance (Liters per second)

The conductance values in the table below have been calculated for air at room temperature using the formulas for tubes and elbows presented in the third edition of Roth's Vacuum Technology: $C_v = 182(D^4/L)^{0.75}$ for viscous flow or $C_m = 12(D^3/L)$ for molecular flow. Port lengths without flanges and inner diameters for the valve sizes and configurations were used. This method is an approximation, use values accordingly.

PORT NOM. OD	ANGLE OR TEE		ANGLE-IN-LINE		IN-LINE		STRAIGHT-THROUGH	
	VISCOUS	MOLECULAR	VISCOUS	MOLECULAR	VISCOUS	MOLECULAR	VISCOUS	MOLECULAR
1/2	60	3	-	-	45	2	-	-
3/4	135	5	120	4	105	4	90	4
1	391	12	286	9	270	8	-	-
1 1/8	-	-	-	-	-	-	436	11
1 1/2	1925	37	1324	25	1263	24	1203	23
2	4677	65	3459	48	3113	44	-	-
2 1/2	12332	136	7505	83	7610	84	-	-
3	23263	217	12558	115	14258	130	-	-
4	57994	396	-	-	34577	236	-	-

Note: $P = \text{air at } 1 \text{ Torr}$. $L = \text{Laxial} + 1.33(9/180)D$ for elbows.

Valve rebuild kits are on page 111

All dimensions are in inches unless otherwise noted

Isolation Valves

Poppet Valve Options



One or more options can be added to a particular valve by adding the option suffix to the basic valve model number as shown below. Heater jackets and controllers are also available for all poppet valves. Call for details and pricing.

Add option suffixes in the following order:

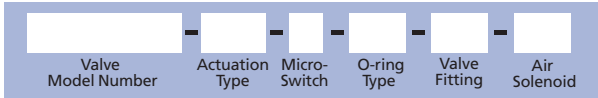

Example of a model number with options: ESVP-1502-CF-AS-M-S11

Actuation Option

OPTION	DESCRIPTION
-A	Air-to-open/air-to-close
-AS	Air-to-open/air-to-close with spring assist
-SA	Spring-to-open/air-to-close

Pneumatic valves with port ODs through 2 inches are normally air-to-open/spring-to-close for immediate closure in case of electrical or air failure. Larger valves are normally air-to-open/air-to close. These actuation options are available on nearly all sizes and port configurations of Nor-Cal pneumatically actuated poppet valves.

Micro-Switch Option

-M
Micro-switches are available on all pneumatically actuated Nor-Cal valves. A pair of 5-amp micro-switches are opened or closed by the movement of the valve stem. One switch closes when the valve is fully open and the other when it is fully closed. These can be connected to control panels with alarms or lights for positive position indication. Electrical leads are approximately 10 inches long, but may be cut to any length upon request.



PORT OD	E
3/8	2.06
1/2	2.06
3/4	2.06
1	2.06
1 1/2	2.06
2	3.54
3	3.54
4	5.01

O-ring Option

OPTION	COMPOUND	TEMPERATURE		APPLICATION
		MIN.	MAX.	
Standard	Viton	-29°C	204°C	Industry standard
-KT	Kalrez 4079	-50°C	316°C	High temperatures
-KC	Kalrez 2037	-54°C	220°C	Chemical resistant
-CR	Chemraz 513	-30°C	210°C	Chemical resistant
-S	Silicone	-55°C	232°C	High temperatures

Standard Nor-Cal valves use chemical resistant Viton O-rings. Viton O-rings should not be heated to above 204°C. Even prolonged exposures of 150°C may degrade the O-rings. High temp Kalrez O-rings allow valve bakeouts to 220°C intermittently or 170°C for extended periods. Silicone O-rings provide adequate sealing performance in thermal cycling from -55°C to 230°C.



Right Angle Valve Fitting Option

OPTION	PROFILE	DESCRIPTION	VALVE PORTS
-F1	Left	1/4 female VCR	Both
-F2	Left	3/8 female VCR	Both
-F3	Left	1/2 female NPT	Bottom
-F4	Right	1/4 female VCR	Both
-F5	Right	3/8 female VCR	Both
-F6	Right	1/2 female NPT	Bottom

Note: Available on ESV, ESVP, CSV and CSVP models only.

All Nor-Cal right angle valves (ESV, CSV, ESVP and CSVP models) are available with the six fitting options described in the table above. These options are designed to make it easy for our customers to retrofit our valves with thermocouple gauges, leak valves, up-to-air valves or gas introduction lines. Other fittings or configurations are available.

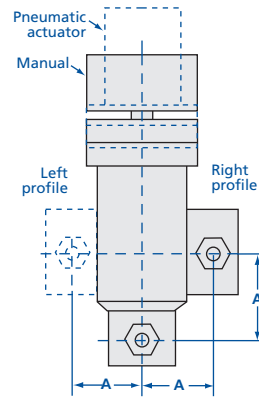

PORT OD	A
3/4	1.50
1	1.22
1 1/2	1.62
2 - 2 1/4	2.25
2 1/2	2.25
3	2.44
4	3.22

Air Solenoid Option

OPTION	KIT	PORT OD	DESCRIPTION
-S11	S11-K	3/8 to 2	3-way, 120VAC, 50/60 Hz
-S21	S21-K	3/8 to 2	3-way, 24VDC
-S31	S31-K	3/8 to 2	3-way, 240VAC, 50/60 Hz
-S41	S41-K	3/8 to 2	3-way, 24VAC, 50/60 Hz
-S12	S12-K	2 1/2 to 3	4-way, 120VAC, 50/60 Hz
-S22	S22-K	2 1/2 to 3	4-way, 24VDC
-S32	S32-K	2 1/2 to 3	4-way, 240VAC, 50/60 Hz
-S42	S42-K	2 1/2 to 3	4-way, 24VAC, 50/60 Hz

Note: Use 4-way solenoid option for 1.12 and 1.5 OD STVP and CSTVP models.

All pneumatic poppet valves can be provided with air solenoids with several current ratings for electropneumatic actuation. Valves with air-to-open, spring-to-close actuation require three-way air solenoids, while air-to-open, air-to-close actuators require four-way solenoids. Both three and four-way air solenoids are available in four current ratings. A pneumatic valve ordered with this option will arrive with an air solenoid installed. Fourteen inch long electrical leads are provided for connection to the power supply.

Air solenoids can be purchased separately in a kit complete with instructions for installation by the customer. When placing your order please specify the model number of the valve that the air solenoid will be installed on, so that our sales staff can confirm whether a three-way or four-way solenoid is required.



Isolation Valves

Manual Angle Valves



SPECIFICATIONS

Port ODs: 3/8 to 3 inches

Materials

Body: Electropolished 304 stainless steel
 Bellows: Welded AM-350 stainless steel
 Bonnet seal: Copper or Viton
 Poppet seal: Viton
Other O-ring compounds available

Actuation: Self-lubricating bronze nuts with ACME threads

Differential pressure

Maximum 20 psia across valve seat

Maximum temperature with Viton seals

Sustained: $\leq 150^{\circ}\text{C}$
 Intermittent: $\leq 204^{\circ}\text{C}$

Vacuum range

Viton bonnet seal: $\geq 1 \times 10^{-9}$ Torr - High Vacuum
 Copper bonnet seal: $\geq 1 \times 10^{-10}$ Torr - UHV

Options: Fittings and O-rings. See page 101

Thermal: Heater jackets and controllers available for all valves. See page 127

Manual Viton Seal Angle Valves

MODEL NUMBER	PORT OD	DESCRIPTION	A	B	C	D
ESV-038	3/8	No flanges	1.50	4.06	4.44	2.25
ESV-0382-CF	3/8	Rotatable 1.33 CF	1.60	4.16	4.54	2.25
ESV-0382-NWB	3/8	NW-10B	1.65	4.21	4.59	2.25
ESV-050	1/2	No flanges	1.50	4.06	4.56	2.25
ESV-0502-CF	1/2	Rotatable 1.33 CF	1.60	4.16	4.66	2.25
ESV-0502-NWB	1/2	NW-10B	1.65	4.21	4.71	2.25
ESV-075	3/4	No flanges	2.00	4.56	5.31	2.25
ESV-0752-CF	3/4	Rotatable 1.33 CF	2.50	5.06	5.81	2.25
ESV-0752-NWB	3/4	NW-16B	2.15	4.71	5.46	2.25
ESV-100	1	No flanges	1.88	4.32	5.32	2.25
ESV-1002-CF	1	Rotatable 2.12 CF	2.05	4.49	5.49	2.25
ESV-1002-NWB	1	NW-25B	2.03	4.47	5.47	2.25
ESV-150	1 1/2	No flanges	2.25	5.63	7.13	3.00
ESV-1502-CF	1 1/2	Rotatable 2.75 CF	2.46	5.84	7.34	3.00
ESV-1502-NWB	1 1/2	NW-40B	2.40	5.78	7.28	3.00
ESV-200	2	No flanges	3.25	7.85	9.85	3.50
ESV-2002-CF	2	Rotatable 3.38 CF	3.48	8.08	10.08	3.50
ESV-2002-NWB	2	NW-50B	3.40	8.00	10.00	3.50
ESV-2002-ASA	2	Rotatable ASA-5-200R	3.50	8.10	10.10	3.50
ESV-250	2 1/2	No flanges	3.00	8.27	10.77	4.00
ESV-2502-CF	2 1/2	Rotatable 4.50 CF	3.38	8.65	11.15	4.00
ESV-2502-ISO	2 1/2	ISO-63-250-OF	3.25	8.52	11.02	4.00
ESV-2502-ASA	2 1/2	Rotatable ASA-5-250R	3.25	8.52	11.02	4.00
ESV-300	3	No flanges	3.25	8.68	11.68	4.50
ESV-3002-CF	3	Rotatable 4.62 CF	3.53	8.96	11.96	4.50
ESV-3002-ISO	3	ISO-80-300-OF	3.50	8.93	11.93	4.50
ESV-3002-ASA	3	Rotatable ASA-6-300R	3.50	8.93	11.93	4.50

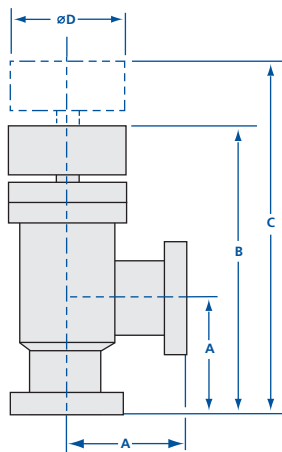

Manual Copper Seal Bonnet Angle Valves

MODEL NUMBER	PORT OD	DESCRIPTION	A	B	C	D
CSV-038	3/8	No flanges	1.50	4.06	4.44	2.73
CSV-0382-CF	3/8	Rotatable 1.33 CF	1.60	4.16	4.54	2.73
CSV-050	1/2	No flanges	1.50	4.06	4.56	2.73
CSV-0502-CF	1/2	Rotatable 1.33 CF	1.60	4.16	4.66	2.73
CSV-075	3/4	No flanges	2.00	4.56	5.31	2.73
CSV-0752-CF	3/4	Rotatable 1.33 CF	2.50	5.06	5.81	2.73
CSV-100	1	No flanges	1.88	4.32	5.32	2.73
CSV-1002-CF	1	Rotatable 2.12 CF	2.05	4.49	5.49	2.73
CSV-150	1 1/2	No flanges	2.25	5.63	7.13	3.25
CSV-1502-CF	1 1/2	Rotatable 2.75 CF	2.46	5.84	7.34	3.25
CSV-200	2	No flanges	3.25	7.85	9.85	4.05
CSV-2002-CF	2	Rotatable 3.38 CF	3.48	8.08	10.08	4.05
CSV-250	2 1/2	No flanges	3.00	8.27	10.77	4.61
CSV-2502-CF	2 1/2	Rotatable 4.50 CF	3.38	8.65	11.15	4.61
CSV-300	3	No flanges	3.25	8.68	11.68	5.62
CSV-3002-CF	3	Rotatable 4.62 CF	3.53	8.96	11.96	5.62

ESV O-ring Kits

MODEL NUMBER	PORT OD
ESV-075-95	3/8-1
ESV-150-95	1 1/2
ESV-200-95	2
ESV-250-95	2 1/2
ESV-300-95	3

CSV O-ring & Gasket Kits

MODEL NUMBER	PORT OD
CSV-075-95	3/8-1
CSV-150-95	1 1/2
CSV-200-95	2
CSV-250-95	2 1/2
CSV-300-95	3



Valve rebuild kits available. See page 111

Pneumatic Viton Seal Angle Valves

MODEL NUMBER	PORT OD	DESCRIPTION	A	B	C	D
ESVP-038	3/8	No flanges	1.50	3.62	5.77	2.25
ESVP-0382-CF	3/8	Rotatable 1.33 CF	1.60	3.72	5.87	2.25
ESVP-0382-NWB	3/8	NW-10B	1.65	3.77	5.92	2.25
ESVP-050	1/2	No flanges	1.50	3.62	5.77	2.25
ESVP-0502-CF	1/2	Rotatable 1.33 CF	1.60	3.72	5.87	2.25
ESVP-0502-NWB	1/2	NW-10B	1.65	3.77	5.92	2.25
ESVP-075	3/4	No flanges	2.00	4.12	6.26	2.25
ESVP-0752-CF	3/4	Rotatable 1.33 CF	2.50	4.62	6.76	2.25
ESVP-0752-NWB	3/4	NW-16B	2.15	4.27	6.41	2.25
ESVP-100	1	No flanges	1.88	3.88	6.02	2.25
ESVP-1002-CF	1	Rotatable 2.12 CF	2.05	4.05	6.19	2.25
ESVP-1002-NWB	1	NW-25B	2.03	4.03	6.17	2.25
ESVP-150	1 1/2	No flanges	2.25	4.98	7.56	3.00
ESVP-1502-CF	1 1/2	Rotatable 2.75 CF	2.46	5.19	7.77	3.00
ESVP-1502-NWB	1 1/2	NW-40B	2.40	5.13	7.71	3.00
ESVP-200	2	No flanges	3.25	6.74	11.23	3.50
ESVP-2002-CF	2	Rotatable 3.38 CF	3.48	6.97	11.46	3.50
ESVP-2002-NWB	2	NW-50B	3.40	6.89	11.38	3.50
ESVP-2002-ASA	2	Rotatable ASA-5-200R	3.50	6.99	11.48	3.50
ESVP-250	2 1/2	No flanges	3.00	7.18	10.10	4.00
ESVP-2502-CF	2 1/2	4.50 CF	3.38	7.56	10.48	4.00
ESVP-2502-ISO	2 1/2	ISO-63-250-OF	3.25	7.43	10.35	4.00
ESVP-2502-ASA	2 1/2	Rotatable ASA-5-250R	3.25	7.43	10.35	4.00
ESVP-300	3	No flanges	3.25	7.62	11.00	4.50
ESVP-3002-CF	3	Rotatable 4.62 CF	3.53	7.90	11.28	4.50
ESVP-3002-ISO	3	ISO-80-300-OF	3.50	7.87	11.25	4.50
ESVP-3002-ASA	3	Rotatable ASA-6-300R	3.50	7.87	11.25	4.50
ESVP-400	4	No flanges	4.22	9.55	14.99	6.50
ESVP-4002-CF	4	Rotatable 6.00 CF	4.66	9.99	15.43	6.50
ESVP-4002-ISO	4	ISO-100-400-OF	4.47	9.80	15.24	6.50
ESVP-4002-ASA	4	Rotatable ASA-7.5-400R	4.47	9.80	15.24	6.50



SPECIFICATIONS

Port ODs: 3/8 to 4 inches

Materials

Body: Electropolished 304 stainless steel
 Bellows: Welded AM-350 stainless steel
 Bonnet seal: Copper or Viton
 Poppet seal: Viton
 Other O-ring compounds available

Actuation: Normally closed

3/8 to 2 inch ODs: Air-to-open, spring-to-close
 2 1/2 to 4 inch ODs: Air-to-open, air-to-close
 See page 101 for more actuation options

Operating pressure: 60 to 80 psig

Differential pressure

Maximum 20 psia across valve seat

Maximum temperature with Viton seals

Sustained: ≤150°C
 Intermittent: ≤204°C

Vacuum range

Viton bonnet seal: ≥1x10⁻⁹Torr - High Vacuum
 Copper bonnet seal: ≥1x10⁻¹⁰Torr - UHV

Options: Fittings, O-rings, air solenoids, micro-switches and actuators. See page 101

Thermal: Heater jackets and controllers available for all valves. See page 127

Pneumatic Copper Seal Bonnet Angle Valves

MODEL NUMBER	PORT OD	DESCRIPTION	A	B	C	D
CSVP-038	3/8	No flanges	1.50	3.75	5.77	2.73
CSVP-0382-CF	3/8	Rotatable 1.33 CF	1.60	3.85	5.82	2.73
CSVP-050	1/2	No flanges	1.50	3.75	5.77	2.73
CSVP-0502-CF	1/2	Rotatable 1.33 CF	1.60	3.85	5.82	2.73
CSVP-075	3/4	No flanges	2.00	4.25	6.26	2.73
CSVP-0752-CF	3/4	Rotatable 1.33 CF	2.50	4.75	6.76	2.73
CSVP-100	1	No flanges	1.88	4.00	6.02	2.73
CSVP-1002-CF	1	Rotatable 2.12 CF	2.05	4.17	6.19	2.73
CSVP-150	1 1/2	No flanges	2.25	4.98	7.56	3.25
CSVP-1502-CF	1 1/2	Rotatable 2.75 CF	2.46	5.19	7.77	3.25
CSVP-200	2	No flanges	3.25	6.62	11.23	4.05
CSVP-2002-CF	2	Rotatable 3.38 CF	3.48	6.85	11.45	4.05
CSVP-250	2 1/2	No flanges	3.00	7.18	10.10	4.61
CSVP-2502-CF	2 1/2	Rotatable 4.50 CF	3.38	7.56	10.48	4.61
CSVP-300	3	No flanges	3.25	7.62	11.00	5.62
CSVP-3002-CF	3	Rotatable 4.62 CF	3.53	7.90	11.28	5.62
CSVP-400	4	No flanges	4.22	9.55	14.99	6.73
CSVP-4002-CF	4	Rotatable 6.00 CF	4.66	9.99	15.43	6.73

ESVP O-Ring Kits

MODEL NUMBER	PORT OD
ESVP-075-95	3/8-1
ESVP-150-95	1 1/2
ESVP-200-95	2
ESVP-250-95	2 1/2
ESVP-300-95	3
ESVP-400-95	4

CSVP O-Ring & Gasket Kits

MODEL NUMBER	PORT OD
CSVP-075-95	3/8-1
CSVP-150-95	1 1/2
CSVP-200-95	2
CSVP-250-95	2 1/2
CSVP-300-95	3
CSVP-400-95	4

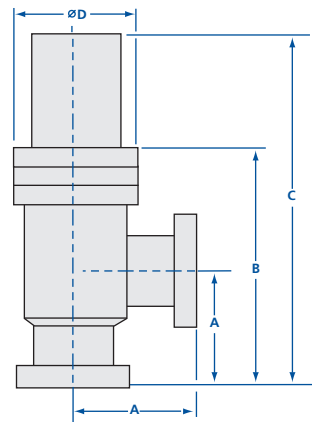

All dimensions are in inches (mm) & weights are in pounds (kg), unless otherwise noted.

Isolation Valves

Manual Angle-In-Line Valves

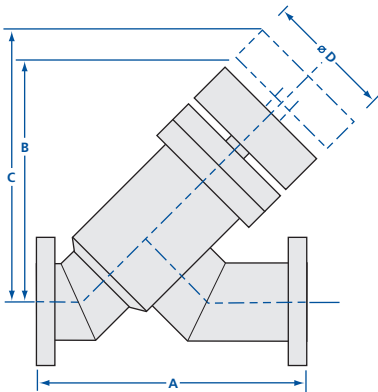

Manual Viton Seal Angle-In-Line Valves

MODEL NUMBER	PORT OD	DESCRIPTION	A	B	C	D
AIV-075	3/4	No flanges	3.70	3.47	4.01	2.25
AIV-0752-CF	3/4	Rotatable 1.33 CF	4.70	3.47	4.01	2.25
AIV-0752-NWB	3/4	NW-16B	4.00	3.47	4.01	2.25
AIV-100	1	No flanges	3.90	3.42	4.14	2.25
AIV-1002-CF	1	Rotatable 2.12 CF	4.23	3.42	4.14	2.25
AIV-1002-NWB	1	NW-25B	4.20	3.42	4.14	2.25
AIV-150	1 1/2	No flanges	4.82	4.55	5.61	3.00
AIV-1502-CF	1 1/2	Rotatable 2.75 CF	5.24	4.55	5.61	3.00
AIV-1502-NWB	1 1/2	NW-40B	5.12	4.55	5.61	3.00
AIV-200	2	No flanges	6.70	6.19	9.15	3.50
AIV-2002-CF	2	Rotatable 3.38 CF	7.15	6.19	9.15	3.50
AIV-2002-NWB	2	NW-50B	7.00	6.19	9.15	3.50
AIV-250	2 1/2	No flanges	7.75	6.99	10.31	4.00
AIV-2502-CF	2 1/2	Rotatable 4.50 CF	8.50	6.99	10.31	4.00
AIV-2502-ISO	2 1/2	ISO-63-250-OF	8.25	6.99	10.31	4.00
AIV-300	3	No flanges	10.05	7.71	11.38	4.50
AIV-3002-CF	3	Rotatable 4.62 CF	10.61	7.71	11.38	4.50
AIV-3002-ISO	3	ISO-80-300-OF	10.55	7.71	11.38	4.50

Manual Copper Seal Bonnet Angle-In-Line Valves

MODEL NUMBER	PORT OD	DESCRIPTION	A	B	C	D
CAIV-075	3/4	No flanges	3.70	3.47	4.01	2.73
CAIV-0752-CF	3/4	Rotatable 1.33 CF	4.70	3.47	4.01	2.73
CAIV-100	1	No flanges	3.90	3.42	4.14	2.73
CAIV-1002-CF	1	Rotatable 2.12 CF	4.48	3.42	4.14	2.73
CAIV-150	1 1/2	No flanges	4.82	4.55	5.61	3.25
CAIV-1502-CF	1 1/2	Rotatable 2.75 CF	5.24	4.55	5.61	3.25
CAIV-200	2	No flanges	6.70	6.19	9.15	4.05
CAIV-2002-CF	2	Rotatable 3.38 CF	7.15	6.19	9.15	4.05
CAIV-250	2 1/2	No flanges	7.75	6.99	10.31	4.61
CAIV-2502-CF	2 1/2	Rotatable 4.50 CF	8.50	6.99	10.31	4.61
CAIV-300	3	No flanges	10.05	7.71	11.38	5.62
CAIV-3002-CF	3	Rotatable 4.62 CF	10.61	7.71	11.38	5.62

SPECIFICATIONS

Port ODs: 3/8 to 3 inches

Materials

Body: Electropolished 304 stainless steel
 Bellows: Welded AM-350 stainless steel
 Bonnet seal: Copper or Viton
 Poppet seal: Viton
Other O-ring compounds available

Actuation: Self-lubricating bronze nuts with ACME threads

Differential pressure

Maximum 20 psia across valve seat

Maximum temperature with Viton seals

Sustained: $\leq 150^{\circ}\text{C}$
 Intermittent: $\leq 204^{\circ}\text{C}$

Vacuum range

Viton bonnet seal: $\geq 1 \times 10^{-9}$ Torr - High Vacuum
 Copper bonnet seal: $\geq 1 \times 10^{-10}$ Torr - UHV

Options: Fittings and O-rings. See page 101

Thermal: Heater jackets and controllers available for all valves. See page 127

AIV O-Ring Kits

MODEL NUMBER	PORT OD
ESV-075-95	3/8-1
ESV-150-95	1 1/2
ESV-200-95	2
ESV-250-95	2 1/2
ESV-300-95	3

CAIVP O-Ring & Gasket Kits

MODEL NUMBER	PORT OD
CSVP-075-95	3/8-1
CSVP-150-95	1 1/2
CSVP-200-95	2
CSVP-250-95	2 1/2
CSVP-300-95	3

All dimensions are in inches (mm) & weights are in pounds (kg), unless otherwise noted.

Isolation Valves

Pneumatic Angle-In-Line Valves



Pneumatic Viton Seal Angle-In-Line Valves

MODEL NUMBER	PORT OD	DESCRIPTION	A	B	C
AIVP-075	3/4	No flanges	3.70	4.32	2.25
AIVP-0752-CF	3/4	Rotatable 1.33 CF	4.70	4.32	2.25
AIVP-0752-NWB	3/4	NW-16B	4.00	4.32	2.25
AIVP-100	1	No flanges	3.90	4.27	2.25
AIVP-1002-CF	1	Rotatable 2.12 CF	4.23	4.27	2.25
AIVP-1002-NWB	1	NW-25B	4.20	4.27	2.25
AIVP-150	1 1/2	No flanges	4.82	5.69	3.00
AIVP-1502-CF	1 1/2	Rotatable 2.75 CF	5.24	5.69	3.00
AIVP-1502-NWB	1 1/2	NW-40B	5.12	5.69	3.00
AIVP-200	2	No flanges	6.70	7.94	3.50
AIVP-2002-CF	2	Rotatable 3.38 CF	7.15	7.94	3.50
AIVP-2002-NWB	2	NW-50B	7.00	7.94	3.50
AIVP-250	2 1/2	No flanges	7.75	7.64	4.00
AIVP-2502-CF	2 1/2	Rotatable 4.50 CF	8.50	7.64	4.00
AIVP-2502-ISO	2 1/2	ISO-63-250-OF	8.25	7.64	4.00
AIVP-300	3	No flanges	10.05	8.70	4.50
AIVP-3002-CF	3	Rotatable 4.62 CF	10.61	8.70	4.50
AIVP-3002-ISO	3	ISO-80-300-OF	10.55	8.70	4.50

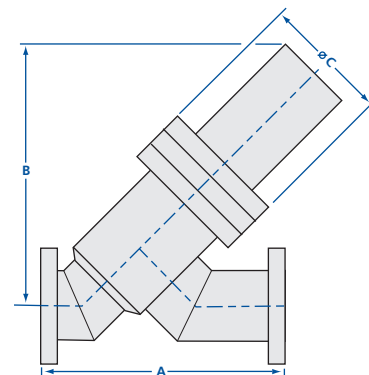

Pneumatic Copper Seal Bonnet Angle-In-Line Valves

MODEL NUMBER	PORT OD	DESCRIPTION	A	B	C
CAIVP-075	3/4	No flanges	3.70	4.32	2.73
CAIVP-0752-CF	3/4	Rotatable 1.33 CF	4.70	4.32	2.73
CAIVP-100	1	No flanges	3.90	4.27	2.73
CAIVP-1002-CF	1	Rotatable 2.12 CF	4.48	4.27	2.73
CAIVP-150	1 1/2	No flanges	4.82	5.69	3.25
CAIVP-1502-CF	1 1/2	Rotatable 2.75 CF	5.24	5.69	3.25
CAIVP-200	2	No flanges	6.70	7.94	4.05
CAIVP-2002-CF	2	Rotatable 3.38 CF	7.15	7.94	4.05
CAIVP-250	2 1/2	No flanges	7.75	7.64	4.61
CAIVP-2502-CF	2 1/2	Rotatable 4.50 CF	8.50	7.64	4.61
CAIVP-300	3	No flanges	10.05	8.70	5.62
CAIVP-3002-CF	3	Rotatable 4.62 CF	10.61	8.70	5.62

SPECIFICATIONS

Port ODs: 3/8 to 3 inches.

Materials

Body: Electropolished 304 stainless steel
 Bellows: Welded AM-350 stainless steel
 Bonnet seal: Copper or Viton
 Poppet seal: Viton
 Other O-ring compounds available

Actuation: Normally closed

3/8 to 2 inch ODs: Air-to-open, spring-to-close
 2 1/2 to 3 inch ODs: Air-to-open, air-to-close
 See page 101 for more actuation options

Operating pressure: 60 to 80 psig

Differential pressure

Maximum 20 psia across valve seat

Maximum temperature with Viton seals

Sustained: ≤150°C
 Intermittent: ≤204°C

Vacuum range

Viton bonnet seal: ≥1x10⁻⁹Torr - High Vacuum
 Copper bonnet seal: ≥1x10⁻¹⁰Torr - UHV

Options: Fittings, O-rings, air solenoids, micro-switches and actuators. See page 101

Thermal: Heater jackets and controllers available for all valves. See page 127

AIVP O-Ring Kits

MODEL NUMBER	PORT OD
ESVP-075-95	3/8-1
ESVP-150-95	1 1/2
ESVP-200-95	2
ESVP-250-95	2 1/2
ESVP-300-95	3

CAIVP O-Ring & Gasket Kits

MODEL NUMBER	PORT OD
CSVP-075-95	3/8-1
CSVP-150-95	1 1/2
CSVP-200-95	2
CSVP-250-95	2 1/2
CSVP-300-95	3

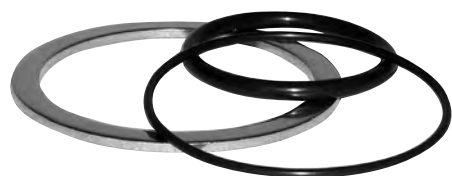

All dimensions are in inches (mm) & weights are in pounds (kg), unless otherwise noted.

Isolation Valves

Manual In-Line Valves



Manual Viton Seal In-Line Valves

MODEL NUMBER	PORT OD	DESCRIPTION	A	B	C	D	E	F
ILV-038	3/8	No flanges	1.50	0.94	1.50	4.06	2.25	4.44
ILV-0382-CF	3/8	Rotatable 1.33 CF	1.60	0.94	1.50	4.06	2.25	4.44
ILV-0382-NWB	3/8	NW-10B	1.65	0.94	1.50	4.06	2.25	4.44
ILV-050	1/2	No flanges	1.50	1.00	1.62	4.19	2.25	4.69
ILV-0502-CF	1/2	Rotatable 1.33 CF	1.60	1.00	1.62	4.19	2.25	4.69
ILV-0502-NWB	1/2	NW-10B	1.65	1.00	1.62	4.19	2.25	4.69
ILV-075	3/4	No flanges	2.00	1.12	1.87	4.44	2.25	5.19
ILV-0752-CF	3/4	Rotatable 1.33 CF	2.50	1.12	1.87	4.44	2.25	5.19
ILV-0752-NWB	3/4	NW-16B	2.15	1.12	1.87	4.44	2.25	5.19
ILV-100	1	No flanges	1.88	1.37	2.25	4.69	2.25	5.69
ILV-1002-CF	1	Rotatable 2.12 CF	2.05	1.37	2.25	4.69	2.25	5.69
ILV-1002-NWB	1	NW-25B	2.03	1.37	2.25	4.69	2.25	5.69
ILV-150	1 1/2	No flanges	2.25	1.88	3.12	6.52	3.00	8.02
ILV-1502-CF	1 1/2	Rotatable 2.75 CF	2.46	1.88	3.12	6.52	3.00	8.02
ILV-1502-NWB	1 1/2	NW-40B	2.40	1.88	3.12	6.52	3.00	8.02
ILV-200	2	No flanges	3.25	2.62	4.12	8.73	3.50	10.73
ILV-2002-CF	2	Rotatable 3.38 CF	3.48	2.62	4.12	8.73	3.50	10.73
ILV-2002-NWB	2	NW-50B	3.40	2.62	4.12	8.73	3.50	10.73
ILV-2002-ASA	2	Rotatable ASA-5-200R	3.50	2.62	4.12	8.73	3.50	10.73
ILV-250	2 1/2	No flanges	3.00	3.12	4.93	10.20	4.00	12.70
ILV-2502-CF	2 1/2	Rotatable 4.50 CF	3.38	3.12	4.93	10.20	4.00	12.70
ILV-2502-ISO	2 1/2	ISO-63-250-OF	3.25	3.12	4.93	10.20	4.00	12.70
ILV-2502-ASA	2 1/2	Rotatable ASA-5-250R	3.25	3.12	4.93	10.20	4.00	12.70
ILV-300	3	No flanges	3.25	3.68	5.62	11.04	4.50	14.04
ILV-3002-CF	3	Rotatable 4.62 CF	3.53	3.68	5.62	11.04	4.50	14.04
ILV-3002-ISO	3	ISO-80-300-OF	3.50	3.68	5.62	11.04	4.50	14.04
ILV-3002-ASA	3	Rotatable ASA-6-300R	3.50	3.68	5.62	11.04	4.50	14.04

SPECIFICATIONS

Port ODs: 3/8 to 3 inches

Materials

Body: Electropolished 304 stainless steel
 Bellows: Welded AM-350 stainless steel
 Bonnet seal: Copper or Viton
 Poppet seal: Viton
Other O-ring compounds available

Actuation: Self-lubricating bronze nuts with ACME threads

Differential pressure

Maximum 20 psia across valve seat

Maximum temperature with Viton seals

Sustained: $\leq 150^{\circ}\text{C}$
 Intermittent: $\leq 204^{\circ}\text{C}$

Vacuum range

Viton bonnet seal: $\geq 1 \times 10^{-9}$ Torr - High Vacuum
 Copper bonnet seal: $\geq 1 \times 10^{-10}$ Torr - UHV

Options: Fittings and O-rings. See page 101

Thermal: Heater jackets and controllers available for all valves. See page 127

Manual Copper Seal Bonnet In-Line Valves

MODEL NUMBER	PORT OD	DESCRIPTION	A	B	C	D	E	F
CILV-038	3/8	No flanges	1.50	0.94	1.50	4.06	2.73	4.44
CILV-0382-CF	3/8	Rotatable 1.33 CF	1.60	0.94	1.50	4.06	2.73	4.44
CILV-050	1/2	No flanges	1.50	1.00	1.62	4.19	2.73	4.69
CILV-0502-CF	1/2	Rotatable 1.33 CF	1.60	1.00	1.62	4.19	2.73	4.69
CILV-075	3/4	No flanges	2.00	1.12	1.87	4.44	2.73	5.19
CILV-0752-CF	3/4	Rotatable 1.33 CF	2.50	1.12	1.87	4.44	2.73	5.19
CILV-100	1	No flanges	1.88	1.37	2.25	4.69	2.73	5.69
CILV-1002-CF	1	Rotatable 2.12 CF	2.05	1.37	2.25	4.69	2.73	5.69
CILV-150	1 1/2	No flanges	2.25	1.88	3.12	6.52	3.25	8.02
CILV-1502-CF	1 1/2	Rotatable 2.75 CF	2.46	1.88	3.12	6.52	3.25	8.02
CILV-200	2	No flanges	3.25	2.62	4.12	8.73	4.05	10.73
CILV-2002-CF	2	Rotatable 3.38 CF	3.48	2.62	4.12	8.73	4.05	10.73
CILV-250	2 1/2	No flanges	3.00	3.12	4.93	10.20	4.61	12.70
CILV-2502-CF	2 1/2	Rotatable 4.50 CF	3.38	3.12	4.93	10.20	4.61	12.70
CILV-300	3	No flanges	3.25	3.62	5.55	11.04	5.62	14.04
CILV-3002-CF	3	Rotatable 4.62 CF	3.53	3.62	5.55	11.04	5.62	14.04

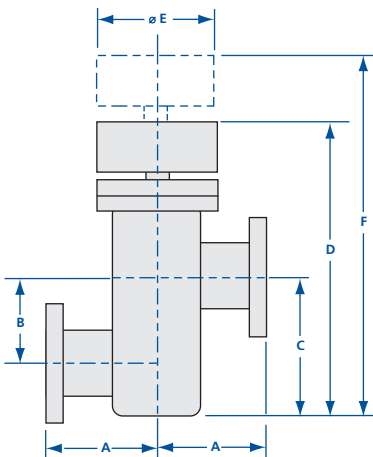

All dimensions are in inches (mm) & weights are in pounds (kg), unless otherwise noted.

CILV O-Ring and Gasket Kits

ILV O-Ring Kits

MODEL NUMBER	PORT OD
ESV-075-95	3/8-1
ESV-150-95	1 1/2
ESV-200-95	2
ESV-250-95	2 1/2
ESV-300-95	3

MODEL NUMBER	PORT OD
CSV-075-95	3/8-1
CSV-150-95	1 1/2
CSV-200-95	2
CSV-250-95	2 1/2
CSV-300-95	3



Pneumatic Viton Seal In-Line Valves

MODEL NUMBER	PORT OD	DESCRIPTION	A	B	C	D	E	F
ILVP-038	3/8	No flanges	1.50	0.94	1.50	3.62	2.25	5.76
ILVP-0382-CF	3/8	Rotatable 1.33 CF	1.60	0.94	1.50	3.62	2.25	5.76
ILVP-0382-NWB	3/8	NW-10B	1.65	0.94	1.50	3.62	2.25	5.76
ILVP-050	1/2	No flanges	1.50	1.00	1.62	3.75	2.25	5.89
ILVP-0502-CF	1/2	Rotatable 1.33 CF	1.60	1.00	1.62	3.75	2.25	5.89
ILVP-0502-NWB	1/2	NW-10B	1.65	1.00	1.62	3.75	2.25	5.89
ILVP-075	3/4	No flanges	2.00	1.12	1.87	4.00	2.25	6.14
ILVP-0752-CF	3/4	Rotatable 1.33 CF	2.50	1.12	1.87	4.00	2.25	6.14
ILVP-0752-NWB	3/4	NW-16B	2.15	1.12	1.87	4.00	2.25	6.14
ILVP-100	1	No flanges	1.88	1.37	2.25	4.25	2.25	6.39
ILVP-1002-CF	1	Rotatable 2.12 CF	2.05	1.37	2.25	4.25	2.25	6.39
ILVP-1002-NWB	1	NW-25B	2.03	1.37	2.25	4.25	2.25	6.39
ILVP-150	1 1/2	No flanges	2.25	1.88	3.12	5.86	3.00	8.45
ILVP-1502-CF	1 1/2	Rotatable 2.75 CF	2.46	1.88	3.12	5.86	3.00	8.45
ILVP-1502-NWB	1 1/2	NW-40B	2.40	1.88	3.12	5.86	3.00	8.45
ILVP-200	2	No flanges	3.25	2.62	4.12	7.62	3.50	12.11
ILVP-2002-CF	2	Rotatable 3.38 CF	3.48	2.62	4.12	7.62	3.50	12.11
ILVP-2002-NWB	2	NW-50B	3.40	2.62	4.12	7.62	3.50	12.11
ILVP-2002-ASA	2	Rotatable ASA-5-200R	3.50	2.62	4.12	7.62	3.50	12.11
ILVP-250	2 1/2	No flanges	3.00	3.12	4.93	9.11	4.00	12.03
ILVP-2502-CF	2 1/2	Rotatable 4.50 CF	3.38	3.12	4.93	9.11	4.00	12.03
ILVP-2502-ISO	2 1/2	ISO-63-250-OF	3.25	3.12	4.93	9.11	4.00	12.03
ILVP-2502-ASA	2 1/2	Rotatable ASA-5-250R	3.50	3.12	4.93	9.11	4.00	12.03
ILVP-300	3	No flanges	3.25	3.68	5.62	9.98	4.50	13.38
ILVP-3002-CF	3	Rotatable 4.62 CF	3.53	3.68	5.62	9.98	4.50	13.38
ILVP-3002-ISO	3	ISO-80-300-OF	3.50	3.68	5.62	9.98	4.50	13.38
ILVP-3002-ASA	3	Rotatable ASA-6-300R	3.50	3.68	5.62	9.98	4.50	13.38
ILVP-400	4	No flanges	4.22	4.88	7.38	12.83	6.50	18.27
ILVP-4002-CF	4	Rotatable 6.00 CF	4.66	4.88	7.38	12.83	6.50	18.27
ILVP-4002-ISO	4	ISO-100-400-OF	4.47	4.88	7.38	12.83	6.50	18.27
ILVP-4002-ASA	4	Rotatable ASA-7.5-400R	4.47	4.88	7.38	12.83	6.50	18.27

SPECIFICATIONS

Port ODs: 3/8 to 4 inches

Materials

Body: Electropolished 304 stainless steel
 Bellows: Welded AM-350 stainless steel
 Bonnet seal: Copper or Viton
 Poppet seal: Viton
 Other O-ring compounds available

Actuation: Normally closed

3/8 to 2 inch ODs: Air-to-open, spring-to-close
 2 1/2 to 4 inch ODs: Air-to-open, air-to-close
 See page 101 for more actuation options

Operating pressure: 60 to 80 psig

Differential pressure

Maximum 20 psia across valve seat

Maximum temperature with Viton seals

Sustained: ≤150°C
 Intermittent: ≤204°C

Vacuum range

Viton bonnet seal: ≥1x 10⁻⁹Torr - High Vacuum
 Copper bonnet seal: ≥1x 10⁻¹⁰Torr - UHV

Options: Fittings, O-rings, air solenoids, micro-switches and actuators. See page 101

Thermal: Heater jackets and controllers available for all valves. See page 127

Pneumatic Copper Seal Bonnet In-Line Valves

MODEL NUMBER	PORT OD	DESCRIPTION	A	B	C	D	E	F
CILVP-038	3/8	No flanges	1.50	0.94	1.50	3.74	2.73	5.76
CILVP-0382-CF	3/8	Rotatable 1.33 CF	1.60	0.94	1.50	3.74	2.73	5.76
CILVP-050	1/2	No flanges	1.50	1.00	1.62	3.88	2.73	5.89
CILVP-0502-CF	1/2	Rotatable 1.33 CF	1.60	1.00	1.62	3.88	2.73	5.89
CILVP-075	3/4	No flanges	2.00	1.12	1.87	4.12	2.73	6.14
CILVP-0752-CF	3/4	Rotatable 1.33 CF	2.50	1.12	1.87	4.12	2.73	6.14
CILVP-100	1	No flanges	1.88	1.37	2.25	4.38	2.73	6.39
CILVP-1002-CF	1	Rotatable 2.12 CF	2.05	1.37	2.25	4.38	2.73	6.39
CILVP-150	1 1/2	No flanges	2.25	1.88	3.12	5.86	3.25	8.44
CILVP-1502-CF	1 1/2	Rotatable 2.75 CF	2.46	1.88	3.12	5.86	3.25	8.44
CILVP-200	2	No flanges	3.25	2.62	4.12	7.50	4.05	12.11
CILVP-2002-CF	2	Rotatable 3.38 CF	3.48	2.62	4.12	7.50	4.05	12.11
CILVP-250	2 1/2	No flanges	3.00	3.12	4.93	9.11	4.61	12.03
CILVP-2502-CF	2 1/2	Rotatable 4.50 CF	3.38	3.12	4.93	9.11	4.61	12.03
CILVP-300	3	No flanges	3.25	3.62	5.55	9.98	5.62	13.38
CILVP-3002-CF	3	Rotatable 4.62 CF	3.53	3.62	5.55	9.98	5.62	13.38
CILVP-400	4	No flanges	4.22	4.88	7.38	12.83	6.73	18.27
CILVP-4002-CF	4	Rotatable 6.00 CF	4.66	4.88	7.38	12.83	6.73	18.27

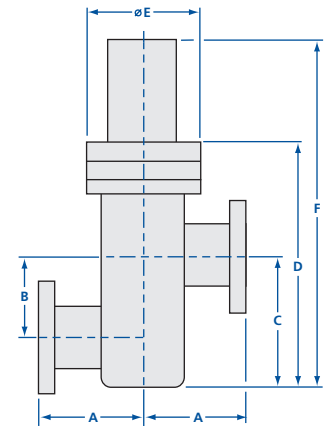

ILVP O-Ring Kits

MODEL NUMBER	PORT OD
ESVP-075-95	3/8-1
ESVP-150-95	1 1/2
ESVP-200-95	2
ESVP-250-95	2 1/2
ESVP-300-95	3
ESVP-400-95	4

CILVP O-Ring & Gasket Kits

MODEL NUMBER	PORT OD
CSVP-075-95	3/8-1
CSVP-150-95	1 1/2
CSVP-200-95	2
CSVP-250-95	2 1/2
CSVP-300-95	3
CSVP-400-95	4

All dimensions are in inches (mm) & weights are in pounds (kg), unless otherwise noted.

Isolation Valves

Manual Tee Valves



Manual Viton Seal Tee Valves

MODEL NUMBER	PORT OD	DESCRIPTION	A	B	C	D
ESV-038T	3/8	No flanges	1.50	4.06	4.44	2.25
ESV-0383T-CF	3/8	Rotatable 1.33 CF	1.60	4.16	4.54	2.25
ESV-0383T-NWB	3/8	NW-10B	1.65	4.21	4.59	2.25
ESV-050T	1/2	No flanges	1.50	4.06	4.56	2.25
ESV-0503T-CF	1/2	Rotatable 1.33 CF	1.60	4.16	4.54	2.25
ESV-0503T-NWB	1/2	NW-10B	1.65	4.21	4.71	2.25
ESV-075T	3/4	No flanges	2.00	4.56	5.31	2.25
ESV-0753T-CF	3/4	Rotatable 1.33 CF	2.50	5.06	5.81	2.25
ESV-0753T-NWB	3/4	NW-16B	2.15	4.71	5.46	2.25
ESV-100T	1	No flanges	1.88	4.32	5.32	2.25
ESV-1003T-CF	1	Rotatable 2.12 CF	2.05	4.49	5.49	2.25
ESV-1003T-NWB	1	NW-25B	2.03	4.47	5.47	2.25
ESV-150T	1 1/2	No flanges	2.25	5.63	7.13	3.00
ESV-1503T-CF	1 1/2	Rotatable 2.75 CF	2.46	5.84	7.34	3.00
ESV-1503T-NWB	1 1/2	NW-40B	2.40	5.78	7.28	3.00
ESV-200T	2	No flanges	3.25	7.85	9.85	3.50
ESV-2003T-CF	2	Rotatable 3.38 CF	3.48	8.08	10.08	3.50
ESV-2003T-NWB	2	NW-50B	3.40	8.00	10.00	3.50
ESV-2003T-ASA	2	Rotatable ASA-5-200R	3.25	8.10	10.10	3.50
ESV-250T	2 1/2	No flanges	3.00	8.27	10.77	4.00
ESV-2503T-CF	2 1/2	Rotatable 4.50 CF	3.38	8.65	11.15	4.00
ESV-2503T-ISO	2 1/2	ISO-63-250-OF	3.25	8.52	11.02	4.00
ESV-2503T-ASA	2 1/2	Rotatable ASA-5-250R	3.25	8.52	11.02	4.00
ESV-300T	3	No flanges	3.25	8.68	11.68	4.50
ESV-3003T-CF	3	Rotatable 4.62 CF	3.53	8.96	11.96	4.50
ESV-3003T-ISO	3	ISO-80-300-OF	3.50	8.93	11.93	4.50
ESV-3003T-ASA	3	Rotatable ASA-6-300R	3.50	8.93	11.93	4.50

SPECIFICATIONS

Port ODs: 3/8 to 3 inches

Materials

Body: Electropolished 304 stainless steel
 Bellows: Welded AM-350 stainless steel
 Bonnet seal: Copper or Viton
 Poppet seal: Viton
 Other O-ring compounds available

Actuation: Self-lubricating bronze nuts with ACME threads

Differential pressure

Maximum 20 psia across valve seat

Maximum temperature with Viton seals

Sustained: $\leq 150^{\circ}\text{C}$
 Intermittent: $\leq 204^{\circ}\text{C}$

Vacuum range

Viton bonnet seal: $\geq 1 \times 10^{-9}$ Torr - High Vacuum
 Copper bonnet seal: $\geq 1 \times 10^{-10}$ Torr - UHV

Options: Fittings and O-rings. See page 101

Thermal: Heater jackets and controllers available for all valves. See page 127

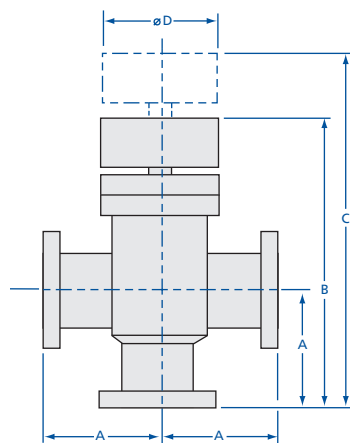

Manual Copper Seal Bonnet Tee Valves

MODEL NUMBER	PORT OD	DESCRIPTION	A	B	C	D
CSV-038T	3/8	No flanges	1.50	4.06	4.44	2.73
CSV-0383T-CF	3/8	Rotatable 1.33 CF	1.60	4.16	4.54	2.73
CSV-050T	1/2	No flanges	1.50	4.06	4.56	2.73
CSV-0503T-CF	1/2	Rotatable 1.33 CF	1.60	4.16	4.66	2.73
CSV-075T	3/4	No flanges	2.00	4.56	5.31	2.73
CSV-0753T-CF	3/4	Rotatable 1.33 CF	2.50	5.06	5.81	2.73
CSV-100T	1	No flanges	1.88	4.32	5.32	2.73
CSV-1003T-CF	1	Rotatable 2.12 CF	2.05	4.49	5.49	2.73
CSV-150T	1 1/2	No flanges	2.25	5.63	7.13	3.25
CSV-1503T-CF	1 1/2	Rotatable 2.75 CF	2.46	5.84	7.34	3.25
CSV-200T	2	No flanges	3.25	7.85	9.85	4.05
CSV-2003T-CF	2	Rotatable 3.38 CF	3.48	8.08	10.08	4.05
CSV-250T	2 1/2	No flanges	3.00	8.27	10.77	4.61
CSV-2503T-CF	2 1/2	Rotatable 3.38 CF	3.38	8.65	11.15	4.61
CSV-300T	3	No flanges	3.25	8.68	11.68	5.62
CSV-3003T-CF	3	Rotatable 4.62 CF	3.53	8.96	11.96	5.62

ESV-T O-Ring Kits

MODEL NUMBER	PORT OD
ESV-075-95	3/8-1
ESV-150-95	1 1/2
ESV-200-95	2
ESV-250-95	2 1/2
ESV-300-95	3

CSV-T O-Ring & Gasket Kits

MODEL NUMBER	PORT OD
CSV-075-95	3/8-1
CSV-150-95	1 1/2
CSV-200-95	2
CSV-250-95	2 1/2
CSV-300-95	3

All dimensions are in inches (mm) & weights are in pounds (kg), unless otherwise noted.

Isolation Valves

Pneumatic Tee Valves



Pneumatic Viton Seal Tee Valves

MODEL NUMBER	PORT OD	DESCRIPTION	A	B	C	D
ESVP-038T	3/8	No flanges	1.50	3.62	5.77	2.25
ESVP-0383T-CF	3/8	Rotatable 1.33 CF	1.60	3.67	5.87	2.25
ESVP-0383T-NWB	3/8	NW-10B	1.65	3.77	5.92	2.25
ESVP-050T	1/2	No flanges	1.50	3.62	5.77	2.25
ESVP-0503T-CF	1/2	Rotatable 1.33 CF	1.60	3.67	5.87	2.25
ESVP-0503T-NWB	1/2	NW-10B	1.65	3.77	5.92	2.25
ESVP-075T	3/4	No flanges	2.00	4.12	6.26	2.25
ESVP-0753T-CF	3/4	Rotatable 1.33 CF	2.50	4.62	6.76	2.25
ESVP-0753T-NWB	3/4	NW-16B	2.15	4.27	6.41	2.25
ESVP-100T	1	No flanges	1.88	3.88	6.02	2.25
ESVP-1003T-CF	1	Rotatable 2.12 CF	2.05	4.05	6.19	2.25
ESVP-1003T-NWB	1	NW-25B	2.03	4.03	6.17	2.25
ESVP-150T	1 1/2	No flanges	2.25	4.98	7.56	3.00
ESVP-1503T-CF	1 1/2	Rotatable 2.75 CF	2.45	5.19	7.77	3.00
ESVP-1503T-NWB	1 1/2	NW-40B	2.40	5.13	7.71	3.00
ESVP-200T	2	No flanges	3.25	6.74	11.23	3.50
ESVP-2003T-CF	2	Rotatable 3.38 CF	3.48	6.97	11.46	3.50
ESVP-2003T-NWB	2	NW-50B	3.40	6.89	11.38	3.50
ESVP-2003T-ASA	2	Rotatable ASA-5-200R	3.50	6.99	11.48	3.50
ESVP-250T	2 1/2	No flanges	3.00	7.18	10.10	4.00
ESVP-2503T-CF	2 1/2	Rotatable 4.50 CF	3.38	7.56	10.48	4.00
ESVP-2503T-ISO	2 1/2	ISO-63-250-OF	3.25	7.43	10.35	4.00
ESVP-2503T-ASA	2 1/2	Rotatable ASA-5-250R	3.25	7.43	10.35	4.00
ESVP-300T	3	No flanges	3.25	7.62	11.00	4.50
ESVP-3003T-CF	3	Rotatable 4.62 CF	3.53	7.90	11.28	4.50
ESVP-3003T-ISO	3	ISO-80-300-OF	3.50	7.87	11.25	4.50
ESVP-3003T-ASA	3	Rotatable ASA-6-300R	3.50	7.87	11.25	4.50
ESVP-400T	4	No flanges	4.22	9.55	14.99	6.50
ESVP-4003T-CF	4	Rotatable 6.00 CF	4.66	9.99	15.43	6.50
ESVP-4003T-ISO	4	ISO-100-400-OF	4.47	9.80	15.24	6.50
ESVP-4003T-ASA	4	Rotatable ASA-7.5-400R	4.47	9.80	15.24	6.50

SPECIFICATIONS

Port ODs: 3/8 to 4 inches

Materials

Body: Electropolished 304 stainless steel
 Bellows: Welded AM-350 stainless steel
 Bonnet seal: Copper or Viton
 Poppet seal: Viton
 Other O-ring compounds available

Actuation:

Normally closed
 3/8 to 2 inch ODs: Air-to-open, spring-to-close
 2 1/2 to 4 inch ODs: Air-to-open, air-to-close
 See page 101 for more actuation options

Operating pressure:

60 to 80 psig
 Differential pressure
 Maximum 20 psia across valve seat

Maximum temperature with Viton seals

Sustained: ≤150°C
 Intermittent: ≤204°C

Vacuum range

Viton bonnet seal: ≥1x 10⁻⁹Torr-High Vacuum
 Copper bonnet seal: ≥1x 10⁻¹⁰Torr - UHV

Options:

Fittings, O-rings, air solenoids, micro-switches and actuators. See page 101

Thermal:

Heater jackets and controllers available for all valves. See page 127

Pneumatic Copper Seal Bonnet Tee Valves

MODEL NUMBER	PORT OD	DESCRIPTION	A	B	C	D
CSVP-038T	3/8	No flanges	1.50	3.75	5.77	2.73
CSVP-0383T-CF	3/8	Rotatable 1.33 CF	1.60	3.85	5.82	2.73
CSVP-050T	1/2	No flanges	1.50	3.75	5.77	2.73
CSVP-0503T-CF	1/2	Rotatable 1.33 CF	1.60	3.85	5.82	2.73
CSVP-075T	3/4	No flanges	2.00	4.25	6.26	2.73
CSVP-0753T-CF	3/4	Rotatable 1.33 CF	2.50	4.75	6.76	2.73
CSVP-100T	1	No flanges	1.88	4.00	6.02	2.73
CSVP-1003T-CF	1	Rotatable 2.12 CF	2.05	4.17	6.19	2.73
CSVP-150T	1 1/2	No flanges	2.25	4.98	7.56	3.25
CSVP-1503T-CF	1 1/2	Rotatable 2.75 CF	2.46	5.19	7.77	3.25
CSVP-200T	2	No flanges	3.25	6.62	11.23	4.05
CSVP-2003T-CF	2	Rotatable 3.38 CF	3.48	6.85	10.58	4.05
CSVP-250T	2 1/2	No flanges	3.00	7.18	10.10	4.61
CSVP-2503T-CF	2 1/2	Rotatable 4.50 CF	3.38	7.56	10.48	4.61
CSVP-300T	3	No flanges	3.25	7.62	11.00	5.62
CSVP-3003T-CF	3	Rotatable 4.62 CF	3.53	7.90	11.28	5.62
CSVP-400T	4	No flanges	4.22	9.55	14.99	6.73
CSVP-4003T-CF	4	Rotatable 6.00 CF	4.66	9.99	15.43	6.73

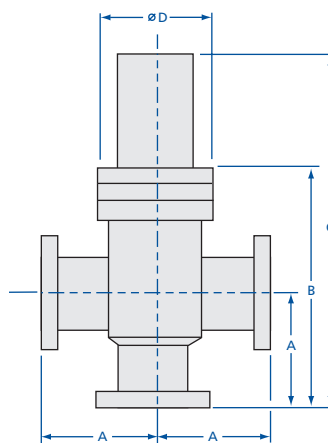

ESVP-T O-Ring Kits

MODEL NUMBER	PORT OD
ESVP-075-95	3/8-1
ESVP-150-95	1 1/2
ESVP-200-95	2
ESVP-250-95	2 1/2
ESVP-300-95	3
ESVP-400-95	4

CSVP-T O-Ring & Gasket Kits

MODEL NUMBER	PORT OD
CSVP-075-95	3/8-1
CSVP-150-95	1 1/2
CSVP-200-95	2
CSVP-250-95	2 1/2
CSVP-300-95	3
CSVP-400-95	4

All dimensions are in inches (mm) & weights are in pounds (kg), unless otherwise noted.

Isolation Valves

Straight-Through Valves

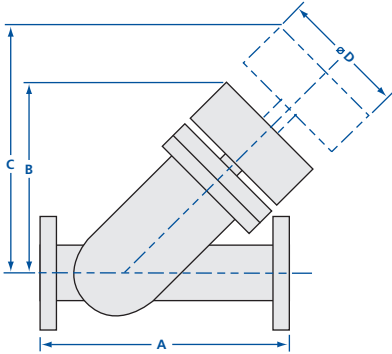

SPECIFICATIONS

Port ODs: 3/4 to 1 1/2 inches

Materials

Body: Electropolished 304 stainless steel
Bellows: Welded AM-350 stainless steel
Bonnet seal: Copper or Viton
Poppet seal: Viton
Other O-ring compounds available

Manual actuation: Self-lubricating bronze nuts with ACME threads

Pneumatic actuation: Normally closed
 3/4 inch ODs: Air-to-open, spring-to-close
 1 1/8 to 1 1/2 inch ODs: Air-to-open, air-to-close
See page 99 for more actuation options

Operating pressure: 60 to 80 psig

Differential pressure

Maximum 20 psia across valve seat

Maximum temperature with Viton seals

Sustained: <150°C
 Intermittent: <204°C

Vacuum range

Viton bonnet seal: >1x 10⁻⁹Torr - High Vacuum
 Copper bonnet seal: >1x 10⁻¹⁰Torr - UHV

Options: Fittings, O-rings, air solenoids, micro-switches and actuators. *See page 101*

Thermal: Heater jackets and controllers available for all valves. *See page 127*

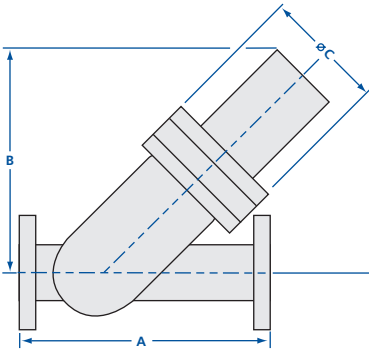

All dimensions are in inches (mm) & weights are in pounds (kg), unless otherwise noted.

Manual Viton Seal Straight-Through Valves

MODEL NUMBER	PORT ID	PORT OD	DESCRIPTION	A	B	C	D
STV-075	0.65	3/4	No flanges	5.00	3.30	4.50	2.25
STV-0752-CF	0.65	3/4	Rotatable 1.33 CF	6.00	3.30	4.50	2.25
STV-0752-NWB	0.65	3/4	NW-16B	5.30	3.30	4.50	2.25
STV-112	1.00	1 1/8	No flanges	5.50	3.86	5.15	3.00
STV-1122-CF	1.00	1 1/8	Rotatable 2.12 CF	5.83	3.86	5.15	3.00
STV-1122-NWB	1.00	1 1/8	NW-40B	5.80	3.86	5.15	3.00
STV-150	1.38	1 1/2	No flanges	7.00	5.47	7.69	3.50
STV-1502-CF	1.38	1 1/2	Rotatable 2.75 CF	7.42	5.47	7.69	3.50
STV-1502-NWB	1.38	1 1/2	NW-40B	7.30	5.47	7.69	3.50

Manual Copper Seal Bonnet Straight-Through Valves

MODEL NUMBER	PORT ID	PORT OD	DESCRIPTION	A	B	C	D
CSTV-075	0.65	3/4	No flanges	5.00	3.51	4.71	2.73
CSTV-0752-CF	0.65	3/4	Rotatable 1.33 CF	6.00	3.51	4.71	2.73
CSTV-150	1.38	1 1/2	No flanges	7.00	5.47	7.69	4.05
CSTV-1502-CF	1.38	1 1/2	Rotatable 2.75 CF	7.42	5.47	7.69	4.05



STV O-Ring Kits

MODEL NUMBER	PORT OD
ESV-075-95	3/4
STV-112-95	1 1/8
STV-150-95	1 1/2

CSTV O-Ring & Gasket Kits

MODEL NUMBER	PORT OD
CSV-075-95	3/4
CSV-150-95	1 1/2

Pneumatic Viton Seal Straight-Through Valves

MODEL NUMBER	PORT ID	PORT OD	DESCRIPTION	A	B	C
STVP-075	0.65	3/4	No flanges	5.00	3.92	2.25
STVP-0752-CF	0.65	3/4	Rotatable 1.33 CF	6.00	3.92	2.25
STVP-0752-NWB	0.65	3/4	NW-16B	5.30	3.92	2.25
STVP-112	1.00	1 1/8	No flanges	5.50	5.10	3.00
STVP-1122-CF	1.00	1 1/8	Rotatable 2.12 CF	5.83	5.10	3.00
STVP-1122-NWB	1.00	1 1/8	NW-40B	5.80	5.10	3.00
STVP-150	1.38	1 1/2	No flanges	7.00	6.11	3.50
STVP-1502-CF	1.38	1 1/2	Rotatable 2.75 CF	7.42	6.11	3.50
STVP-1502-NWB	1.38	1 1/2	NW-40B	7.30	6.11	3.50

Pneumatic Copper Seal Bonnet Straight-Through Valves

MODEL NUMBER	PORT ID	PORT OD	DESCRIPTION	A	B	C
CSTVP-075	0.65	3/4	No flanges	5.00	3.92	2.73
CSTVP-0752-CF	0.65	3/4	Rotatable 1.33 CF	6.00	3.92	2.73
CSTVP-150	1.38	1 1/2	No flanges	7.00	6.11	4.05
CSTVP-1502-CF	1.38	1 1/2	Rotatable 2.75 CF	7.42	6.11	4.05

STVP O-Ring Kits

MODEL NUMBER	PORT OD
ESVP-075-95	3/4
STVP-112-95	1 1/8
STVP-150-95	1 1/2

CSTVP O-Ring & Gasket Kits

MODEL NUMBER	PORT OD
CSV-075-95	3/4
CSTVP-150-95	1 1/2

Isolation Valves

Replacement Parts & Rebuild Kits



Complete Valve Rebuild Kits

Contains all items except valve body (#7), refer to kit contents diagram at right.

MODEL NUMBER	FOR VALVE MODEL NUMBERS
CSV-075-99	CSV, CILV and CAIV, -038 to -100
CSV-150-99	CSV, CILV and CAIV-150
CSV-200-99	CSV, CILV and CAIV-200
CSV-250-99	CSV, CILV and CAIV-250
CSV-300-99	CSV, CILV and CAIV-300
CSVP-075-99	CSVP, CILVP and CAIVP, -038 to -100
CSVP-150-99	CSVP, CILVP and CAIVP-150
CSVP-200-99	CSVP, CILVP and CAIVP-200
CSVP-250-99	CSVP, CILVP and CAIVP-250
CSVP-300-99	CSVP, CILVP and CAIVP-300
CSVP-400-99	CSVP, CILVP and CAIVP-400
ESV-075-99	ESV, ILV, AIV, STV, -038 to -100
ESV-150-99	ESV, ILV, AIV, STV, -150
ESV-200-99	ESV, ILV and AIV-200
ESV-250-99	ESV, ILV and AIV-250
ESV-300-99	ESV, ILV and AIV-300
ESVP-075-99	ESVP, ILVP, AIVP, STVP, -038 to -100
ESVP-150-99	ESVP, ILVP, AIVP, STVP, -150
ESVP-200-99	ESVP, ILVP and AIVP-200
ESVP-250-99	ESVP, ILVP and AIVP-250
ESVP-300-99	ESVP, ILVP and AIVP-300
ESVP-400-99	ESVP, ILVP and AIVP-400
STV-112-99	STV-112
STVP-112-99	STVP-112
STV-150-99	STV-150
STVP-150-99	STVP-150

Kit Contents Diagram

1. Air cylinder
 2. Stem O-ring*
 3. Retaining plate
 4. Center plate
 5. Stem shaft
 6. Set screw
 7. Body
 8. Air filter
 9. Air cylinder spring
 10. Jam nut
 11. Spring retainer
 12. Piston cup
 13. Bonnet screws
 14. Air cylinder O-ring
 15. Body flange O-ring or gasket
 16. Bellows assembly
 17. Poppet O-ring
- * 2 inch ID valves are assembled with two stem O-rings.

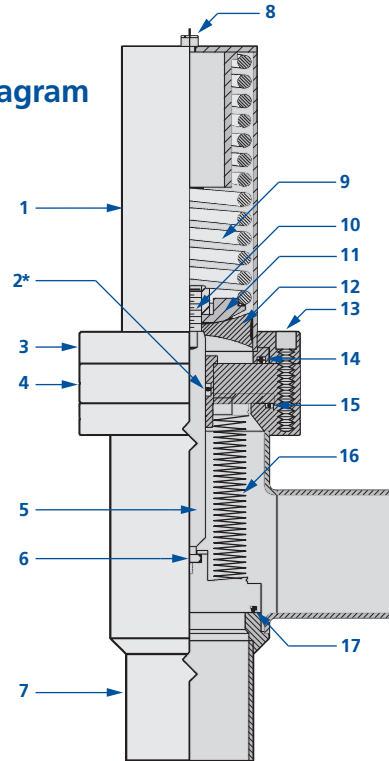

O-Ring or Gasket Kits

MODEL NUMBER	KIT CONTENTS (See drawing)	FOR VALVE MODEL NUMBERS
ESV-075-95	2, 14, 15, 17	ESV, AIV, ILV, ESV-T, STV, -038 to -100
ESV-150-95	2, 14, 15, 17	ESV, AIV, ILV, ESV-T, -150
ESV-200-95	2, 14, 15, 17	ESV, AIV, ILV, ESV-T, -200
ESV-250-95	2, 14, 15, 17	ESV, AIV, ILV, ESV-T, -250
ESV-300-95	2, 14, 15, 17	ESV, AIV, ILV, ESV-T, -300
STV-112-95	2, 14, 15, 17	STV-112
STV-150-95	2, 14, 15, 17	STV-150
ESVP-075-95	2, 14, 15, 17	ESVP, AIVP, ILVP, ESVP-T, STVP, -038 to -100
ESVP-150-95	2, 14, 15, 17	ESVP, AIVP, ILVP, ESVP-T, -150
ESVP-200-95	2, 14, 15, 17	ESVP, AIVP, ILVP, ESVP-T, -200
ESVP-250-95	2, 14, 15, 17	ESVP, AIVP, ILVP, ESVP-T, -250
ESVP-300-95	2, 14, 15, 17	ESVP, AIVP, ILVP, ESVP-T, -300
ESVP-400-95	2, 14, 15, 17	ESVP, AIVP, ILVP, ESVP-T, -400
STVP-112-95	2, 14, 15, 17	STVP-112
STVP-150-95	2, 14, 15, 17	STVP-150
CSV-075-95	2, 14, 15, 17	CSV, CAIV, CILV, CSTV, -038 to -100
CSV-150-95	2, 14, 15, 17	CSV, CAIV, CILV, -150
CSV-200-95	2, 14, 15, 17	CSV, CAIV, CILV, -200
CSV-250-95	2, 14, 15, 17	CSV, CAIV, CILV, -250
CSV-300-95	2, 14, 15, 17	CSV, CAIV, CILV, -300
CSTV-150-95	2, 14, 15, 17	CSTV-150
CSVP-075-95	2, 14, 15, 17	CSVP, CAIVP, CILVP, CSTVP, -038 to -100
CSVP-150-95	2, 14, 15, 17	CSVP, CAIVP, CILVP, -150
CSVP-200-95	2, 14, 15, 17	CSVP, CAIVP, CILVP, -200
CSVP-250-95	2, 14, 15, 17	CSVP, CAIVP, CILVP, -250
CSVP-300-95	2, 14, 15, 17	CSVP, CAIVP, CILVP, -300
CSVP-400-95	2, 14, 15, 17	CSVP, CAIVP, CILVP, -400
CSTVP-150-95	2, 14, 15, 17	CSTVP-150

Bellows Assembly Kits

MODEL NUMBER	CONTENTS (See drawing)	FOR VALVE MODEL NUMBERS
CSV-075-16K	6, 16, 17	CSV, CILV, CAIV, CSTV, manual or pneumatic, -038 to -100
CSV-150-16K	6, 16, 17	CSV, CILV, CAIV, CSTV, manual or pneumatic, -150
CSV-200-16K	6, 16, 17	CSV, CILV, CAIV, manual or pneumatic, -200
CSV-250-16K	6, 16, 17	CSV, CILV, CAIV, manual or pneumatic, -250
CSV-300-16K	6, 16, 17	CSV, CILV, CAIV, manual or pneumatic, -300
CSVP-400-16K	6, 16, 17	CSVP and CILVP-400
ESV-075-16K	6, 16, 17	ESV, ILV and AIV, manual or pneumatic, -038 to -100
ESV-150-16K	6, 16, 17	ESV, ILV and AIV-150, manual or pneumatic
ESV-200-16K	6, 16, 17	ESV, ILV and AIV-200, manual
ESVP-200-16K	6, 16, 17	ESVP, ILVP and AIVP-200, pneumatic
ESV-250-16K	6, 16, 17	ESV, ILV and AIV-250, manual
ESVP-250-16K	6, 16, 17	ESV, ILV and AIV-250, pneumatic
ESV-300-16K	6, 16, 17	ESV, ILV and AIV-300, manual
ESVP-300-16K	6, 16, 17	ESV, ILV and AIV-300, pneumatic
ESVP-400-16K	16, 17	ESV, ILV and AIV-400, manual or pneumatic





Isolation Valves

Ball Valves

SPECIFICATIONS

Port OD's: ¾, 1, 1 ½ and 2 inches

Materials:

Body: 304 stainless steel

Ball: 316L stainless steel

Stem seal: Viton

(other O-ring compounds available)

Ball seal: Teflon

Actuation: Manual and pneumatic/spring

Leak Rates: <1x10⁻⁹ std.cc/sec He to atmosphere,
<1x10⁻⁷ std.cc/sec He across the seat.

Operating Temperature: 150°C Max.

Supply Pressure (pneumatic/spring version):
80-100 psig

Vacuum Range: 1000 to 1x10⁻⁴ Torr

Options: Heater jackets and controllers
available for all valves.

Ball valves are a low cost, manually or pneumatically operated, straight through isolation device. Their simple, robust design provides high reliability in "dirty" applications. They are commonly used on MOCVD and CVD equipment downstream from the chamber or vacuum pump to isolate traps or abatement tools. A stainless steel body and Teflon seat make these valves ideal for corrosive environments. A quarter turn of the handle quickly switches the valve from open to close. They are available with NW-16 through NW-50 flanges as standards. Heater jackets are available to reduce process by-product accumulation.



Ball Valve Options

Please use the following part numbering tree to add the appropriate options to a standard ball valve model number. See tables below for option codes.

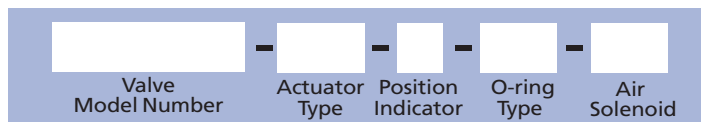

Example: BVP-2003-NW-O-S21

Pneumatic ball valve with 1.25 inch bore, NW-50 flanges, air-to-open/spring-to-close, position indicators and 24VDC air solenoid.

O-ring Material Option

CODE	DESCRIPTION
Default (no code)	Viton
-K79	Kalrez 4079
-K85	Kalrez 8085
-K75	Kalrez 8575
-K91	Kalrez 9100
-C38	Chemraz E38
-D19	Dupra 192
-PP7	Perlast G74P

Actuator Option - BVM

CODE	DESCRIPTION
(Default)	Non-locking handle
-L	Locking handle

Air Solenoid Option - BVP

CODE	KIT	DESCRIPTION
-S11	BVP-S11-K	120VAC, 50/60 Hz
-S21	BVP-S21-K	24VDC
-S31	BVP-S31-K	240VAC, 50/60 Hz
-S41	BVP-S41-K	24VAC, 50/60 Hz
-S12	BVP-S12-K	120VAC, 50/60 Hz (Use with -A actuator option)
-S22	BVP-S22-K	24VDC (Use with -A actuator option)
-S32	BVP-S32-K	240VAC, 50/60 Hz (Use with -A actuator option)
-S42	BVP-S42-K	24VAC, 50/60 Hz (Use with -A actuator option)

Actuator Option - BVP

DESCRIPTION	CODE
Air-to-Open/Spring-to-Close (Normally Closed)	(Default)
Spring-to-Open/Air-to-Close (Normally Open)	-SA
Air-to-Open/Air-to-Close	-A

Position Indicator Option - BVP

Open/closed position indicators detect the valve position. 24 VDC powered.

DESCRIPTION	CODE
Optical sensor	-O

All dimensions are in inches (mm) & weights are in pounds (kg), unless otherwise noted.



Manual Ball Valve - BVM

MODEL NUMBER	PORT OD	BALL ID	DESCRIPTION	A	B	C	D	E	F
BVM-0751	0.75 (19)	0.56 (14)	No Flanges	3.17 (81)	1.85 (47)	2.87 (73)	1.85 (47)	5.63 (143)	0.93 (24)
BVM-0751-NW	0.75 (19)	0.56 (14)	NW-16	3.47 (88)	1.85 (47)	2.87 (73)	1.85 (47)	5.63 (143)	0.93 (24)
BVM-1001-NW	0.75 (19)	0.56 (14)	NW-25	3.93 (100)	1.85 (47)	2.87 (73)	1.85 (47)	5.63 (143)	0.93 (24)
BVM-1002	1.0 (25)	0.85 (21.6)	No Flanges	3.63 (92)	2.13 (54)	3.26 (83)	1.90 (48)	6.00 (152)	0.98 (25)
BVM-1002-NW	1.0 (25)	0.85 (21.6)	NW-25	3.93 (100)	2.13 (54)	3.26 (83)	1.90 (48)	6.00 (152)	0.98 (25)
BVM-1502-NW	1.0 (25)	0.85 (21.6)	NW-40	4.66 (118)	2.13 (54)	3.26 (83)	1.90 (48)	6.00 (152)	0.98 (25)
BVM-1503	1.5 (38)	1.25 (31.8)	No Flanges	4.36 (111)	2.80 (71)	3.97 (101)	2.80 (71)	7.00 (178)	1.40 (36)
BVM-1503-NW	1.5 (38)	1.25 (31.8)	NW-40	4.66 (118)	2.80 (71)	3.97 (101)	2.80 (71)	7.00 (178)	1.40 (36)
BVM-2003-NW	1.5 (38)	1.25 (31.8)	NW-50	4.97 (126)	2.80 (71)	3.97 (101)	2.80 (71)	7.00 (178)	1.40 (36)
BVM-2004	2.0 (51)	1.50 (38)	No Flanges	4.67 (119)	-	-	-	-	-
BVM-2004-NW	2.0 (51)	1.50 (38)	NW-50	4.97 (126)	-	-	-	-	-

Call for information on larger sizes.

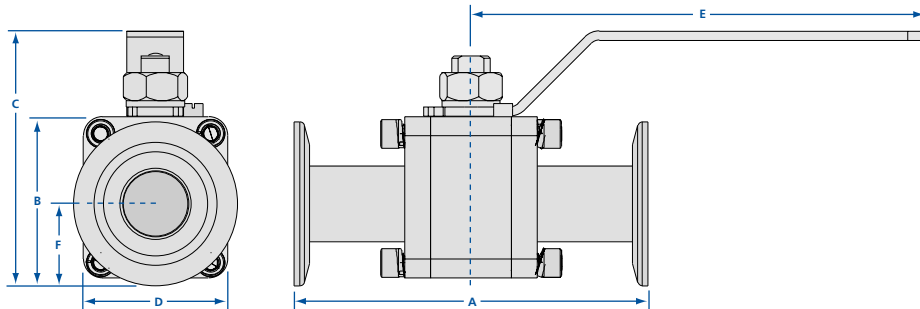

SPECIFICATIONS

Port OD's: 3/4, 1, 1 1/2 and 2 inches

Materials:

Body: 304 stainless steel
Ball: 316L stainless steel
Stem seal: Viton
(other O-ring compounds available)
Ball seal: Teflon

Actuation: Manual and pneumatic/spring

Leak Rates: <1x10⁻⁹ std.cc/sec He to atmosphere, <1x10⁻⁷ std.cc/sec He across the seat.

Operating Temperature: 150°C Max.

Supply Pressure (pneumatic/spring version): 80-100 psig

Vacuum Range: 1000 to 1x10⁻⁴ Torr

Options: Heater jackets and controllers available for all valves.

Pneumatic Ball Valve - BVP

MODEL NUMBER	PORT OD	BALL ID	DESCRIPTION	A	B	C	D	E	F
BVP-0751	0.75 (19)	0.56 (14)	No Flanges	3.17 (81)	10.20 (259)	6.67 (169)	1.85 (47)	3.00 (76)	0.93 (24)
BVP-0751-NW	0.75 (19)	0.56 (14)	NW-16	3.47 (88)	10.20 (259)	6.67 (169)	1.85 (47)	3.00 (76)	0.93 (24)
BVP-1001-NW	0.75 (19)	0.56 (14)	NW-25	3.93 (100)	10.20 (259)	6.67 (169)	1.85 (47)	3.00 (76)	0.93 (24)
BVP-1002	1.0 (25)	0.85 (21.6)	No Flanges	3.63 (92)	11.98 (304)	7.43 (189)	1.90 (48)	3.28 (83)	0.98 (25)
BVP-1002-NW	1.0 (25)	0.85 (21.6)	NW-25	3.93 (100)	11.98 (304)	7.43 (189)	1.90 (48)	3.28 (83)	0.98 (25)
BVP-1502-NW	1.0 (25)	0.85 (21.6)	NW-40	4.66 (118)	11.98 (304)	7.43 (189)	1.90 (48)	3.28 (83)	0.98 (25)
BVP-1503	1.5 (38)	1.25 (31.8)	No Flanges	4.36 (111)	11.98 (304)	8.10 (206)	2.80 (71)	3.28 (83)	1.40 (36)
BVP-1503-NW	1.5 (38)	1.25 (31.8)	NW-40	4.66 (118)	11.98 (304)	8.10 (206)	2.80 (71)	3.28 (83)	1.40 (36)
BVP-2003-NW	1.5 (38)	1.25 (31.8)	NW-50	4.97 (126)	11.98 (304)	8.10 (206)	2.80 (71)	3.28 (83)	1.40 (36)
BVP-2004	2.0 (51)	1.50 (38)	No Flanges	4.67 (119)	-	-	-	-	-
BVP-2004-NW	2.0 (51)	1.50 (38)	NW-50	4.97 (126)	-	-	-	-	-

Call for information on larger sizes.

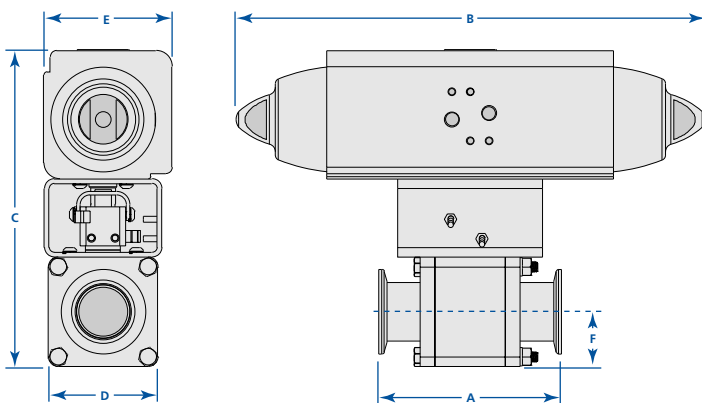

Ball Valve Seal Kit

MODEL NUMBER	DESCRIPTION
BVM-1-95	Flange, ball & stem seals
BVM-2-95	Flange, ball & stem seals
BVM-3-95	Flange, ball & stem seals
BVM-4-95	Flange, ball & stem seals

Ball Valve Rebuild Kit

MODEL NUMBER	DESCRIPTION
BVM-1-99	SS ball & seal kit
BVM-2-99	SS ball & seal kit
BVM-3-99	SS ball & seal kit
BVM-4-99	SS ball & seal kit

All dimensions are in inches (mm) & weights are in pounds (kg), unless otherwise noted.

Isolation Valves

Genesis Modular Valves



SPECIFICATIONS

Port ODs: 3/4 to 2 inches.
Larger sizes and metric tubing diameters available on request

Mating flange: NW-16 through 50 standard

Air fittings: 5/32 inch One-Touch

Materials

Body: Electroless nickel coated aluminum

Bellows: Welded AM-350 stainless steel

O-rings: Viton standard

Other compounds available.

Air cylinder: Teflon coated aluminum

Service interval: One million cycles

Actuation: Air-to-open/spring-to-close

Operating pressure: 60-80 psi required

Differential pressure: 25 psia maximum across poppet

Helium leak rate: 1x10⁻⁹ Torr standard cc./sec. maximum

Operating temperature

Sustained: ≤150°C

Intermittent: ≤204°C

Options: Soft Start actuator with or without orifice, position indicators, air solenoids, and various O-ring compounds

Thermal: Heaters and insulators available.
See page 120

The Genesis modular vacuum valve system provides equipment designers with unlimited possibilities for downstream vacuum subassemblies. Nippleless valve bodies and block fittings can be assembled by two attachment methods using universal ISO-KF centering ring/O-ring hardware, providing maximum flexibility and the smallest footprint possible.

Simple and robust, Genesis valves are rated at one million cycles before service. During testing, these valves were cycled millions of times while maintaining vacuum integrity. The welded bellows is AM-350 stainless steel for corrosion resistance, longevity and flexibility. The bellows fully retract from the side port when the valve is open, eliminating buildup of process by-products on the bellows and subsequent particle generation during operation. Valve center plates have been eliminated in order to provide precise alignment between the poppet and valve seat. A composite stem bushing resists wear even at high temperatures. Valve return springs are shot peened in order to provide millions of cycles without loss of force. Teflon coated air cylinders feature a 15 micron air filter to prevent particle migration either into or out of the air cylinder.

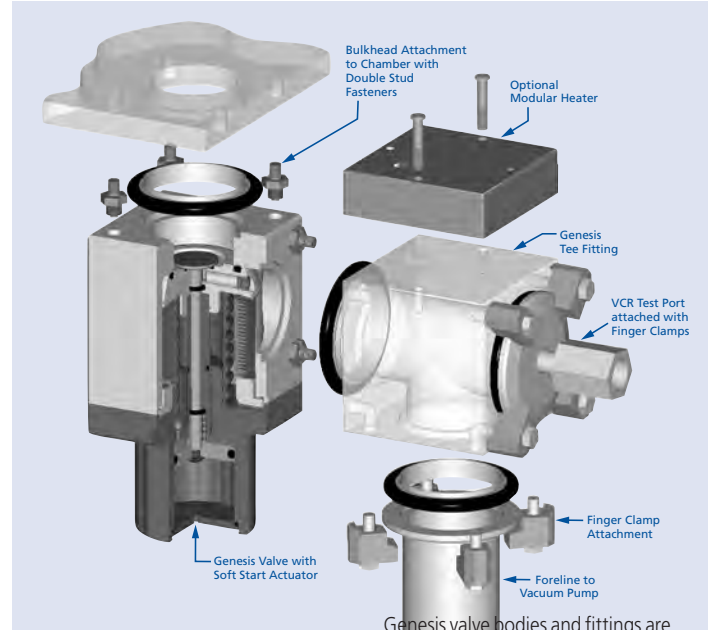

Genesis valve bodies and fittings are electroless nickel coated aluminum for excellent thermal characteristics and corrosion resistance. Components are machined from solid 6061-T6 aluminum to eliminate welds, leak paths and entrapments. All tapped holes are supplied with stainless steel threaded inserts for long term serviceability.

Genesis valves and fittings have a patented nippleless body, which provides the highest conductance and smallest footprint available. Air solenoids, open/closed position indicators, and soft start actuators can be added with no addition to size. All valves are designed for easy O-ring or bellows replacement. Design symmetry allows the air actuator to be oriented at 90° increments for easy access to the air solenoid and visibility of position indicators.

Genesis Aluminum Modular Valves

MODEL NUMBER	PORT SIZE	FLANGE	A	B	C	D	THREAD	BOLT CIRCLE
GNV-072	3/4	NW-16	1.15	2.31	3.04	1.46	12-24	2.031
GNV-102	1	NW-25	1.06	2.13	3.14	1.46	12-24	2.031
GNV-152	1 1/2	NW-40	1.25	2.50	3.71	1.88	12-24	2.616
GNV-202	2	NW-50	1.63	3.25	4.44	2.25	1/4-20	3.406

Note: For option descriptions and how to add options, see next page.

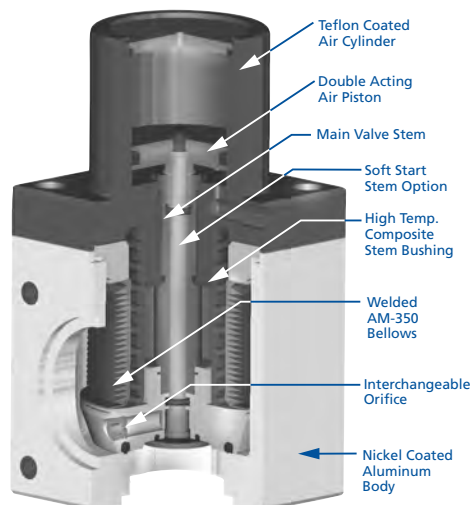
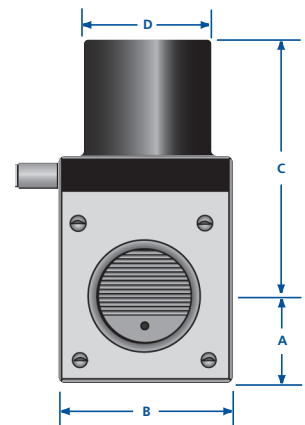

Heaters, insulators, replacement parts and valve rebuild kits are located on Page 120

All dimensions are in inches (mm) & weights are in pounds (kg), unless otherwise noted.

Conductance

The conductance values in the table below have been calculated for air at room temperature using the formulas for tubes and elbows presented in the third edition of Roth's Vacuum Technology: $C_v = 182(D^4/L')\bar{P}$ for viscous flow or $C_m = 12(D^3/L')$ for molecular flow, Port lengths without flanges and inner diameters for the valve sizes and configurations were used. This method is an approximation, use values accordingly.

GENESIS VALVE	MOLECULAR FLOW C_m (LITERS/SEC.)	VISCOUS FLOW C_v (LITERS/SEC.)
GNV-10	21	717
GNV-15	59	3115
GNV-20	114	8183

Note: \bar{P} =air at 1 Torr. L' =Laxial +1.33(0/180)D for elbows.

Isolation Valves

Genesis Modular Valve Options



Follow this part tree to add one or more options to a Genesis valve.

Add options to the basic valve part number in the order shown. **Example: GNV-152-S2-P10-KT-B21**

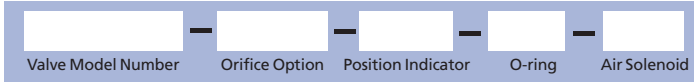

Soft Start Valve Actuator Option

For reduced particle contamination in load locks and process chambers, Genesis valves can be provided with a patented low cost soft start actuator with no increase in valve size. A double-acting air piston, opens a soft start circuit inside the valve when air is supplied to the top of the air cylinder. The soft start by-pass opening can be provided fully open or with a specified orifice, depending on the desired pumpdown. (See diagram.) After the chamber has been pumped from atmosphere to the desired cross over pressure, the main valve circuit is opened by supplying air to the bottom of the air cylinder. Each circuit can be operated independently and is air-to-open, spring-to-close.

Orifice Option

OPTION	VALVE SIZE	ORIFICE SIZE
-S0	No orifice	
-S1	3/4 to 2	.147
-S2	3/4 to 2	.109
-S3	3/4 to 2	.070

NOTE: Refer to diagrams for orifice selection

Orifice Parts & Kits

MODEL NUMBER	VALVE SIZE	ORIFICE SIZE
GNV-075-SO-1	3/4 to 2	.070
GNV-075-SO-2	3/4 to 2	.109
GNV-075-SO-3	3/4 to 2	.147
GNV-075-SO-K	3/4 to 2	Kit*
GNV-075-SO-T	All	Wrench

* Kits include all orifice sizes and an installation wrench for the specified valve size

Position Indicator Option

Nor-Cal's CE certified, shielded, open/closed position indicators detect the piston position in the valve's air cylinder. The technician has a visual indication of power to the circuit (12 to 24 VDC) and the valve position, as does the operator watching the panel. With the soft start option only one position indicator can be provided for the fully open position. Operating temperature range is -25°C to 70°C for valves with position indicators. Call for more information on heated valves with position indicators.

OPTION	VALVE ACTUATOR	DESCRIPTION
-P10	Soft Start/Standard	1 position indicator - main valve open only
-P1C	Standard	1 position indicator - main valve closed only
-P2	Standard	2 position indicators - main valve open & closed

Refer to diagram below for dimensions.

Air Solenoid & Position Indicator Dimensions

SIZE	A	B	C	D
3/4	2.55	4.82	3.76	1.66
1	2.55	4.82	3.76	1.66
1 1/2	2.73	5.31	4.06	1.82
2	3.11	6.05	4.42	2.03

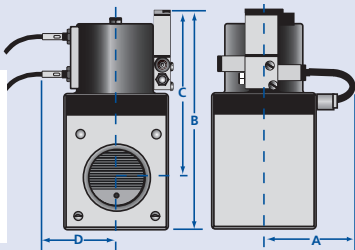

O-ring Option

Genesis modular valves use chemical resistant Viton O-rings for closure. Viton O-rings should not be heated to above 204°C. Even prolonged exposures of 150°C may degrade the O-rings. High temp Kalrez O-rings allow valve bakeouts to 220°C intermittently or 170°C for extended periods. Silicone O-rings provide adequate sealing performance in thermal cycling from -55°C to 230°C.

OPTION	COMPOUND	TEMPERATURE MIN.	TEMPERATURE MAX.	DESCRIPTION
Standard	Viton	-29°C	204°C	Industry standard
-KT	Kalrez 4079	-50°C	316°C	High temperatures
-KC	Kalrez 2037	-54°C	220°C	Chemical resistant
-CR	Chemraz 513	-30°C	210°C	Chemical resistant
-S	Silicone	-55°C	232°C	Extreme temps

Valve/Orifice Pumpdown Curves Charts

Diagram A - TYPICAL PUMP-DOWN WITH SOFT-START
1 1/2 or 2 inch valve on 30 Liter Chamber

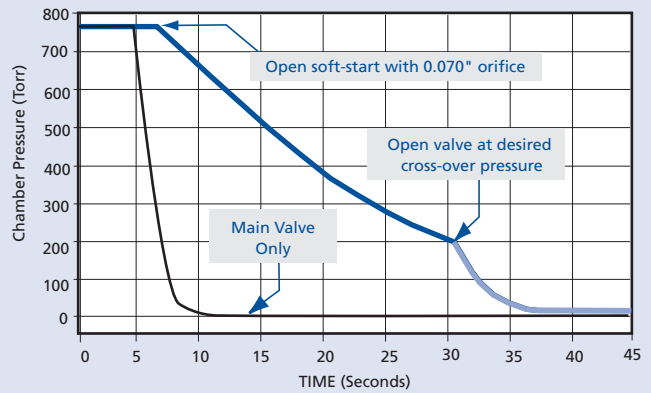

1 1/2 & 2 inch valves tested on a 30 liter chamber

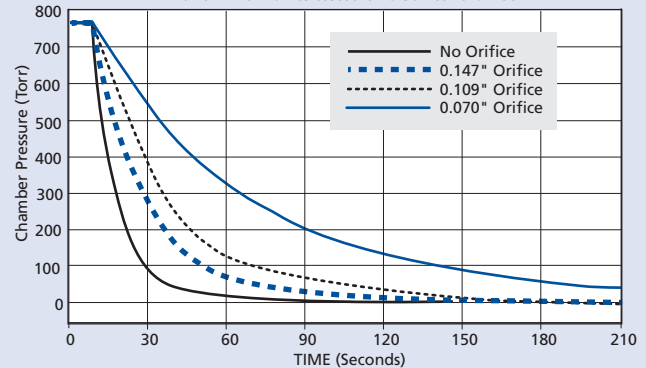

Air Solenoid Option

Low 1.8 wattage, CE certified air solenoids in several current ratings can be provided on the valve, ready to attach to the house air supply. One three-way air solenoid is required for a standard Genesis valve and two three-way air solenoids are required for a soft start version. This option includes 24 inch quick disconnect electrical leads and 5/32 inch one-touch air fittings. Remote mount required on heated valves. Air solenoids can also be supplied as a kit with assembly hardware and instructions. Kit part numbers are in the second column below.

OPTION	KIT	ACTUATOR	DESCRIPTION	QUANTITY
-A11	A11-K	Standard	120 VAC, 50/60 Hz	1
-A21	A21-K	Standard	24 VDC	1
-A31	A31-K	Standard	240 VAC, 50/60 Hz	1
-A41	A41-K	Standard	24 VAC, 50/60 Hz	1
-B11	B11-K	Soft Start	120 VAC, 50/60 Hz	2
-B21	B21-K	Soft Start	24 VDC	2
-B31	B31-K	Soft Start	240 VAC, 50/60 Hz	2
-B41	B41-K	Soft Start	24 VAC, 50/60 Hz	2

Refer to diagram at left for dimensions.

Valve heaters, insulators, rebuild and replacement part kits are located on page 120

Isolation Valves

Genesis Modular Valve Assembly Hardware

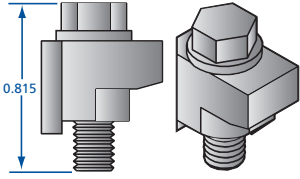

Finger Clamp Component Assembly

Stainless steel finger clamps allow a standard ISO-KF flange to be attached directly to a Genesis valve or fitting using a standard ISO-KF centering ring and O-ring. Elbows, reducers, chamber ports, roughing lines, or other vacuum components can be attached directly to valve bodies or fittings with finger clamps. Unnecessary valve ports have been eliminated, shortening the gas path and increasing system conductance. For ultimate versatility standard nipples and elbows can be attached with finger clamps in order to make a drop-in replacement valve, such as an angle-in-line or tee valve. Once the finger clamp bolt is loosened it can be pivoted out of the way in order to remove or install the flange and centering ring. The finger clamp does not need to be removed from the valve or fitting. The clamp is self-aligning when tightened, for ease of flange installation. Each kit contains four finger clamps, hex head bolts and washers for one connection.

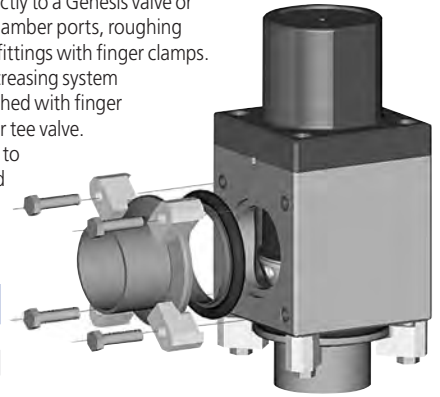

MODEL NUMBER	VALVE SIZE	BOLT	TORQUE
GNCP-150-S	3/4 to 1 1/2	12-24 x 7/8	60 in/lb
GNCP-200-S	2	1/4-20 x 7/8	100 in/lb

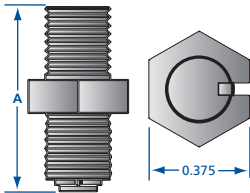

Block Subassemblies with Double Stud Fasteners

Stainless steel double stud fasteners allow two Genesis components to be connected using a standard ISO-KF centering ring and O-ring. Special subassemblies, such as diverter valves or roughing/high vacuum circuits can be assembled quickly using double stud fasteners with valves and block fittings. These subassemblies can be provided as a unit from Nor-Cal or you may choose to assemble them from individual components. They are ideal for limited space installations, such as on cluster tool frames, and provide highest conductance, while eliminating unnecessary hardware. Double stud fasteners can be used to make a bulkhead attachment from a valve directly to a chamber. Stud fasteners can be installed using a jeweler's screwdriver and a 3/8 inch ignition wrench. An installation tool for stud fasteners is provided with each stud fastener kit or assembly, or one can be purchased separately. Each kit contains four double stud fasteners for one connection and an installation tool.

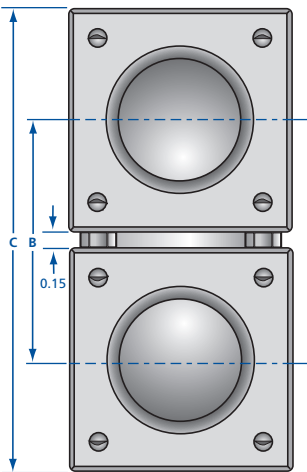
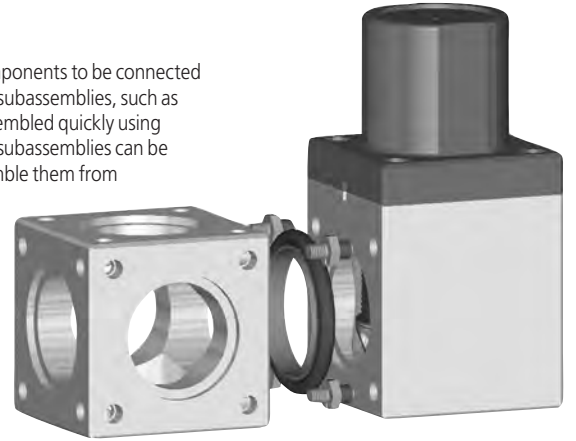

MODEL NUMBER	VALVE SIZE	DESCRIPTION	THREAD	A	B	C
GNSF-150	3/4 to 1	(4) double stud fasteners	12-24	0.625	2.28	4.40
GNSF-150	1 1/2	(4) double stud fasteners	12-24	0.625	2.65	5.15
GNSF-150-K	3/4 to 1 1/2	(4) double stud fasteners with install tool	12-24	0.625	-	-
GNSF-200	2	(4) double stud fasteners	1/4-20	0.730	3.40	6.65
GNSF-200-K	2	(4) double stud fasteners with install tool	1/4-20	0.730	-	-
GNSF-T	All	Double stud install tool	-	-	-	-

Valve heaters, insulators, rebuild and replacement part kits are located on page 120

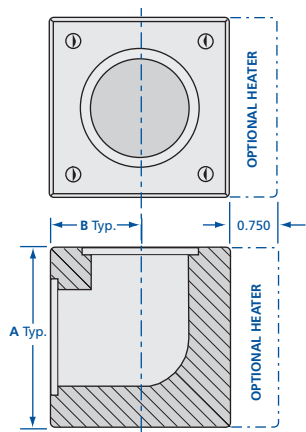

Genesis Modular Fittings

Genesis fittings provide the most compact, highest conductance, corrosion resistant vacuum connection available when used with Genesis valves, fittings and double stud fasteners. These fittings can also attach with finger clamps to standard ISO-KF components with universal O-rings, which are also available from Nor-Cal Products.

90° Elbow

MODEL NUMBER	VALVE SIZE	A	B	THREAD	BOLT CIRCLE
GNF-102	1	2.125	1.063	12-24	2.031
GNF-152	1½	2.500	1.250	12-24	2.616
GNF-202	2	3.250	1.625	¼-20	3.406

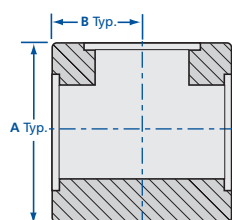

Tee

MODEL NUMBER	VALVE SIZE	A	B	THREAD	BOLT CIRCLE
GNF-103	1	2.125	1.063	12-24	2.031
GNF-153	1½	2.500	1.250	12-24	2.616
GNF-203	2	3.250	1.625	¼-20	3.406

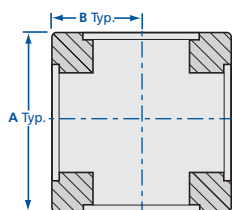

4-Way Cross

MODEL NUMBER	VALVE SIZE	A	B	THREAD	BOLT CIRCLE
GNF-104	1	2.125	1.063	12-24	2.031
GNF-154	1½	2.500	1.250	12-24	2.616
GNF-204	2	3.250	1.625	¼-20	3.406

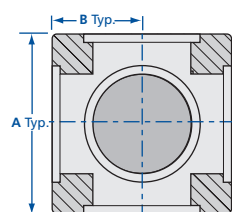

5-Way Cross

MODEL NUMBER	VALVE SIZE	A	B	THREAD	BOLT CIRCLE
GNF-105	1	2.125	1.063	12-24	2.031
GNF-155	1½	2.500	1.250	12-24	2.616
GNF-205	2	3.250	1.625	¼-20	3.406

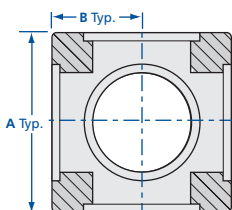

6-Way Cross

MODEL NUMBER	VALVE SIZE	A	B	THREAD	BOLT CIRCLE
GNF-106	1	2.125	1.063	12-24	2.031
GNF-156	1½	2.500	1.250	12-24	2.616
GNF-206	2	3.250	1.625	¼-20	3.406

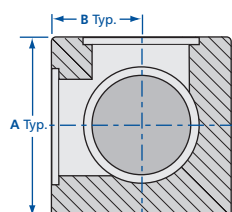

Tri-Bow

MODEL NUMBER	VALVE SIZE	A	B	THREAD	BOLT CIRCLE
GNF-107	1	2.125	1.063	12-24	2.031
GNF-157	1½	2.500	1.250	12-24	2.616
GNF-207	2	3.250	1.625	¼-20	3.406

SPECIFICATIONS

Port ODs: 1, 1½ and 2 inches. *Other sizes and metric tubing diameters available*

Body: Electroless nickel coated 6061 T-6 aluminum with SS threaded inserts

O-rings: Viton standard

Assembly

Fitting to fitting: Double-stud fasteners
Fitting to flange: Finger clamps

Helium leak rate: 1x10⁻⁹ Torr standard cc./sec. maximum

Operating temperature

Sustained: 150°C
Intermittent: 204°C

Options: Modular heaters and heater jackets

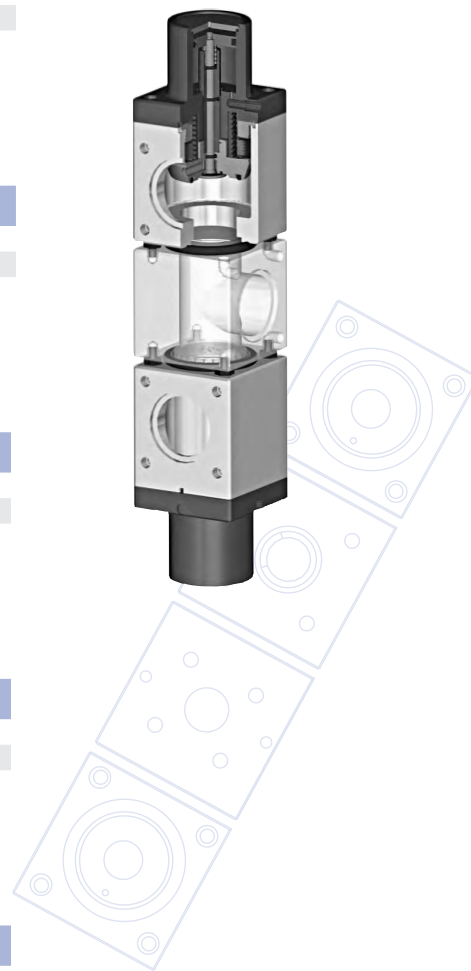

Heaters and insulators are available on page 120



Isolation Valves

Genesis Stainless Steel Valves

Genesis stainless steel poppet valves offer equipment designers the high performance and optimized conductance of Genesis modular valves in Nor-Cal's standard stainless steel poppet valve body. These simple, robust valves are available with standard and soft start air-to-open/spring-to-close actuation in port sizes from 3/4 to 4 inches. Viton O-ring seals are standard. Other O-ring compounds, open/closed position indicators and air solenoids are available as options. Heater jackets and insulators are also available.

During testing, the valves were cycled millions of times while maintaining vacuum integrity. The welded bellows is AM-350 for corrosion resistance, longevity and flexibility. The bellows fully retracts from the side port when the valve is open, eliminating buildup of process by-products on the bellows and subsequent particle generation during operation. Valve center plates have been eliminated in order to provide precise alignment between the poppet and valve seat. A composite stem bushing resists wear even at high temperatures. Valve return springs are shot peened in order to provide millions of cycles without loss of force. Teflon coated air cylinders feature a 15 micron air filter to prevent particle migration either into or out of the air cylinder. All valves are designed for easy O-ring or bellows replacement. Design symmetry allows the air actuator to be oriented at 90° increments for easy access to the air solenoid and visibility of position indicators.

For reduced particle contamination in load locks and process chambers, Genesis stainless steel valves are offered with a patented low cost soft start actuator with no increase in valve size. A double-acting air piston, opens a soft start circuit inside the valve when air is supplied to the top of the air cylinder. The soft start by-pass opening can be provided fully open or with a specified orifice, depending on the desired pump down. After the chamber has been pumped from atmosphere to the desired cross over pressure, the main valve circuit is opened by supplying air to the bottom of the air cylinder. Each circuit can be operated independently and is air-to-open/spring-to-close. Soft start Genesis stainless steel valves are offered standard with no orifice. Various orifice size options and multiple size orifice kits are available. See next page.

SPECIFICATIONS

Port ODs: 3/4 to 4 inches.
Larger sizes and metric tubing diameters available on request

Mating flanges: NW-16 through ISO-100 standard

Air fittings: 3/32 inch One-Touch

Materials

Body: 304 stainless steel
Bellows: Welded AM-350 stainless steel
O-rings: Viton standard
(Other compounds available.)
Air cylinder: Teflon coated aluminum

Service interval: One million cycles

Actuation: Normally closed
Air-to-open/spring-to-close

Operating pressure: 60-80 psi required

Differential pressure: 20 psi maximum across poppet

Helium leak rate: 1x10⁻⁹ Torr standard cc./sec. maximum

Operating temperature
Sustained: ≤150°C
Intermittent: ≤204°C

Option: Air solenoids, open/closed position indicators, soft start with various orifice sizes and various O-ring compounds



Conductance

This table has been calculated in liters per second for air at room temperature using the formulas for tubes and elbows presented in the third edition of Roth's Vacuum Technology.

$C_v = 182(D^4/L')\bar{P}$ for viscous flow or $C_m = 12(D^3/L')$ for molecular flow

Note: Calculations were based on port lengths without flanges and inner diameters for the valve sizes and configurations.
P = air at 1 Torr
L' = Laxial + 1.33(θ/180)D for elbows.

PORT OD	ANGLE		ANGLE-IN-LINE	
	VISCOUS	MOLECULAR	VISCOUS	MOLECULAR
1/2	60	3	-	-
3/4	135	5	120	4
1	391	12	285	9
1 1/8	-	-	-	-
1 1/2	1925	37	1324	25
2	4677	65	3459	48
2 1/2	12332	136	7505	83
3	23763	217	12558	115
4	57994	396	-	-

Genesis Stainless Steel Angle Valves

MODEL NUMBER	ACTUATION	FLANGE TYPE	PORT OD	A	B	C	D	E
GNVS-072-NWB	Standard	NW-16	3/4	1.50	3.40	4.78	1.46	2.13
GNVS-072-NWB-50	Soft Start	NW-16	3/4	1.50	3.40	4.78	1.46	2.13
GNVS-102-NWB	Standard	NW-25	1	2.42	4.19	5.57	1.46	2.13
GNVS-102-NWB-50	Soft Start	NW-25	1	2.42	4.19	5.57	1.46	2.13
GNVS-152-NWB	Standard	NW-40	1 1/2	2.49	4.51	6.20	1.88	2.50
GNVS-152-NWB-50	Soft Start	NW-40	1 1/2	2.49	4.51	6.20	1.88	2.50
GNVS-202-NWB	Standard	NW-50	2	3.22	5.56	7.66	2.25	3.25
GNVS-202-NWB-50	Soft Start	NW-50	2	3.22	5.56	7.66	2.25	3.25
GNVS-302-ISO	Standard	ISO-80	3	3.86	7.33	10.85	4.13	5.45
GNVS-302-ISO-50	Soft Start	ISO-80	3	3.86	7.33	10.85	4.13	5.45
GNVS-402-ISO	Standard	ISO-100	4	4.25	8.38	13.04	5.00	6.40
GNVS-402-ISO-50	Soft Start	ISO-100	4	4.25	8.38	13.04	5.00	6.40

Genesis Stainless Steel Angle-In-Line Valves

MODEL NUMBER	ACTUATION	FLANGE TYPE	PORT OD	A	B	C	D	E
GNVSAI-072-NWB	Standard	NW-16	3/4	4.20	3.76	4.37	1.46	2.13
GNVSAI-072-NWB-50	Soft Start	NW-16	3/4	4.20	3.76	4.37	1.46	2.13
GNVSAI-102-NWB	Standard	NW-25	1	4.00	3.85	4.63	1.46	2.13
GNVSAI-102-NWB-50	Soft Start	NW-25	1	4.00	3.85	4.63	1.46	2.13
GNVSAI-152-NWB	Standard	NW-40	1 1/2	5.12	4.47	5.28	1.88	2.50
GNVSAI-152-NWB-50	Soft Start	NW-40	1 1/2	5.12	4.47	5.28	1.88	2.50
GNVSAI-202-NWB	Standard	NW-50	2	7.00	5.79	7.00	2.25	3.25
GNVSAI-202-NWB-50	Soft Start	NW-50	2	7.00	5.79	7.00	2.25	3.25
GNVSAI-302-ISO	Standard	ISO-80	3	10.55	8.88	11.62	4.13	5.45
GNVSAI-302-ISO-50	Soft Start	ISO-80	3	10.55	8.88	11.62	4.13	5.45
GNVSAI-402-ISO	Standard	ISO-100	4	12.00	10.75	13.81	5.00	6.40
GNVSAI-402-ISO-50	Soft Start	ISO-100	4	12.00	10.75	13.81	5.00	6.40

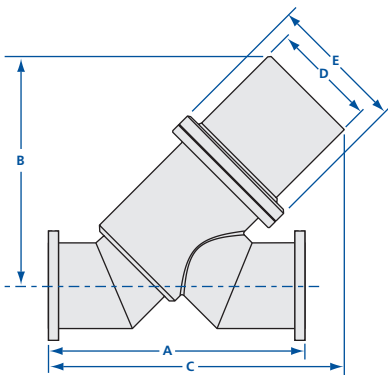
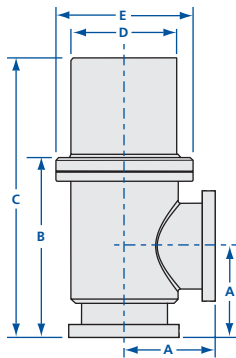

Valve rebuild and replacement part kits are available on page 120

Isolation Valves

Genesis Stainless Steel Valve Options



Follow this part tree to add one or more options to a Genesis valve.
Add options to the basic valve part number in the order shown.



Example: **GNVSAI-302-ISO-P10-KT-A11**

Orifice Option

Genesis stainless steel valves with Soft Start actuation come standard with no orifice. To order these valves with an orifice replace the "S0" part number suffix with one of the following options. Example: Change standard valve part number **GNVS-072-NWB-S0** to **GNVS-072-NWB-S1**.

ORIFICE OPTION	VALVE SIZE	ORIFICE SIZE	ORIFICE REPLACEMENTS	VALVE SIZE	ORIFICE SIZE
-S0		No orifice	GNV-075-S0-1	3/4 to 2	.070
-S1	3/4 to 2	.147	GNV-075-S0-2	3/4 to 2	.109
-S2	3/4 to 2	.109	GNV-075-S0-3	3/4 to 2	.147
-S3	3/4 to 2	.070	GNV-300-S0-1	3 & 4	.055
-S4	3 & 4	.055	GNV-300-S0-2	3 & 4	.093
-S5	3 & 4	.093	GNV-300-S0-3	3 & 4	.128
-S6	3 & 4	.128	GNV-300-S0-4	3 & 4	.201
-S7	3 & 4	.201	GNV-075-S0-K	3/4 to 2	Kit*
			GNV-300-S0-K	3 & 4	Kit*
			GNV-075-S0-T	3/4 to 4	Wrench

NOTE: Refer to diagrams for orifice option selection

* Kits include all orifice sizes and an installation wrench for the specified valve size

Open/Closed Position Indicator Option

Nor-Cal's CE certified, shielded, open/closed position indicators detect the piston position in the valve's air cylinder. The technician has a visual indication of power to the circuit (12 to 24 VDC) and the valve position, as does the operator watching the panel. With the soft start option only one position indicator can be provided for the fully open position. Operating temperature range is -25°C to 70°C for valves with position indicators. Call for more information on high temperature position indicators.

OPTION	VALVE ACTUATOR	DESCRIPTION
-P10	Soft Start/Standard	1 position indicator - main valve open only
-P1C	Standard	1 position indicator - main valve closed only
-P2	Standard	2 position indicators - main valve open & closed

O-ring Option

Standard Genesis valves are furnished with Viton O-rings are resistant to most chemicals, but should not be heated to temperatures in excess 204°C. Even prolonged exposures of 150°C may degrade the O-rings. High temperature Kalrez O-rings allow the valve to be heated to 220°C intermittently or 170°C for prolonged periods.

OPTION	COMPOUND	APPLICATIONS
-KT	4079 Kalrez	High temperature
-KC	2037 Kalrez	Chemical resistant
-CR	513 Chemraz	Chemical resistant
-S	Silicone	Extreme temperatures



Valve/Orifice Pumpdown Curves Charts

1 1/2 & 2 inch valves tested on a 30 liter chamber

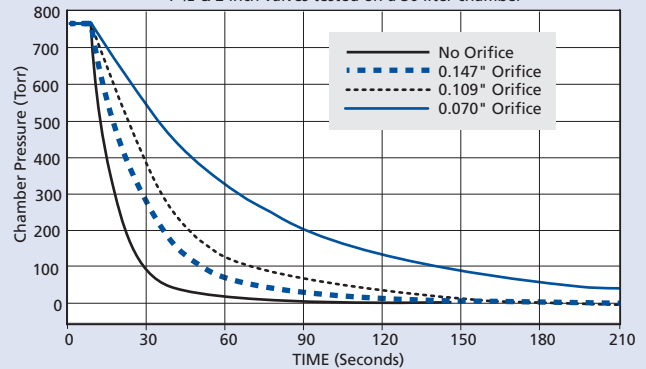

3 and 4 inch valves tested with various Soft-Start orifices on a 30 liter chamber and 232 CFM Edwards mechanical blower pump package.

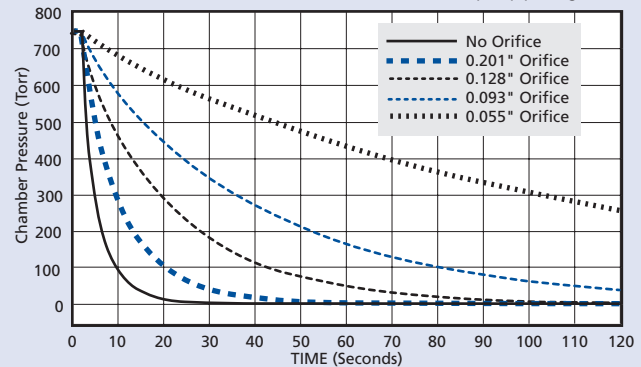

Air Solenoid Option

Low 1.8 wattage, CE certified three-way air solenoids can be provided on the valve in several electrical current ratings, with 24 inch quick disconnect electrical leads, and 5/32 inch one-touch air fittings - ready to attach to the house air supply. One solenoid is required for standard Genesis stainless valves. Two solenoids are required for soft start versions. Remote mount is required on heated valves. Air solenoid kits with assembly hardware and instructions are available. Kit part numbers are in the second column below.

OPTION	KIT	ACTUATOR	DESCRIPTION	QUANTITY
-A11	A11-K	Standard	120 VAC, 50/60 Hz	1
-A21	A21-K	Standard	24 VDC	1
-A31	A31-K	Standard	240 VAC, 50/60 Hz	1
-A41	A41-K	Standard	24 VAC, 50/60 Hz	1
-B11	B11-K	Soft Start	120 VAC, 50/60 Hz	2
-B21	B21-K	Soft Start	24 VDC	2
-B31	B31-K	Soft Start	240 VAC, 50/60 Hz	2
-B41	B41-K	Soft Start	24 VAC, 50/60 Hz	2



Isolation Valves

Genesis Heaters & Replacement Kits

SPECIFICATIONS

Compatible Valves: Genesis Modular Valves
Heaters and controllers for stainless steel Genesis Valves available. Call for details.

Insulator Body: 1/2 inch thick, trimable, molded silicone construction. Touch safe exterior

Heater

Voltage: 120 or 240 VAC standard
Set points: 120°C or 150°C
Manual reset: 200°C with over temp shutoff
Low temperature alert: standard on 1 1/2 and 2 inch valves

Connections

Power cord: 12 inch with AMP 3-pin
Alert cords: Two 12 inch with AMP MR connectors standard on 1 1/2 & 2 inch valves

Certification

Insulators: UL 94 V-O
Heaters: UL listed. CE certification pending

Genesis Modular Valve Heaters & Insulators

A unique, UL listed modular heater provides 120°C or 150°C internal temperatures in valves or fittings at a fraction of the cost of other heaters. Genesis heaters use thick film technology to provide uniform heat throughout the component. Each heater contains a control set point and a resettable high temperature shut off. The 1 1/2 and 2 inch sizes also have a low temperature alert that can be connected to a remote alarm. Each thermostat can be replaced without destroying the heater. The same heater can be attached to a valve body or fitting with two screws. A trim-to-fit, molded insulator covers the heated component and mating flanges. These clean room compatible insulators are constructed of 1/2 inch thick molded silicone. When in use, the exterior surface remains touch-safe. Insulators meet UL 94 V-O requirements. Insulators for other components are available upon request. Heater jackets and controllers for Genesis Stainless Steel Valves are available. Call for information and pricing.

Heaters

MODEL NUMBER	VALVE SIZE	SET POINT	WATTS	A
HT-GN-100-120-1	3/4 & 1	120°C	120	2.13
HT-GN-100-150-1	3/4 & 1	150°C	120	2.13
HT-GN-150-120-1	1 1/2	120°C	120	2.50
HT-GN-150-150-1	1 1/2	150°C	120	2.50
HT-GN-200-120-1	2	120°C	160	3.25
HT-GN-200-150-1	2	150°C	160	3.25

NOTE: Replace "-1" with "-2" for 240V heaters.

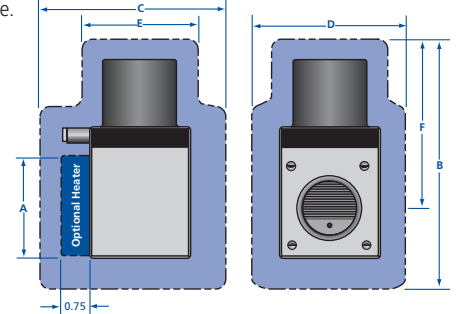

Heater Insulators

MODEL NUMBER	VALVE SIZE	B	C	D	E	F
HI-GNV-100	3/4 & 1	6.00	4.50	3.13	2.50	3.64
HI-GNV-150	1 1/2	6.63	5.00	3.63	2.88	4.25
HI-GNV-200	2	8.00	5.88	4.38	3.31	5.00

Heater Power Cords

MODEL NUMBER	LENGTH
HT-GN-PCD-6	6 ft.
HT-GN-PCD-12	12 ft.

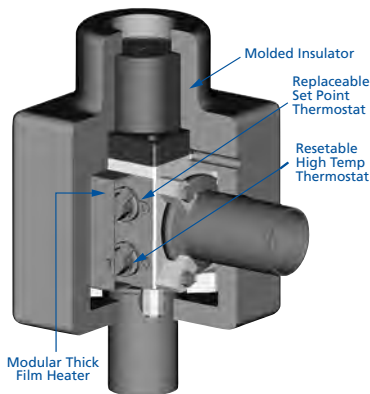

Genesis Valve Assembly Kits and Replacement Hardware

The kits below are for use with Genesis modular valves and with Genesis stainless steel valves. First maintenance is recommended at one million cycles, depending on the cleanliness of the process. Typical valve service will require O-ring replacement.

Bellows Assembly Kits

Includes bellows, top flange and poppet weldment assembly. Requires O-ring kit to seal.

KIT NUMBER	VALVE SIZE	ACTUATOR
GNV-100-16	3/4 & 1	Standard
GNV-100-16-S0	3/4 & 1	Soft Start
GNV-150-16	1 1/2	Standard
GNV-150-16-S0	1 1/2	Soft Start
GNV-200-16	2	Standard
GNV-200-16-S0	2	Soft Start
GNV-300-16	3	Standard
GNV-300-16-S0	3	Soft Start
GNV-400-16	4	Standard
GNV-400-16-S0	4	Soft Start

Viton O-Ring Kits

Includes bellows O-ring and poppet O-ring.

Other O-ring compounds are available on request.

KIT NUMBER	VALVE SIZE	ACTUATOR
GNV-100-95	3/4 & 1	Standard
GNV-100-95-S0	3/4 & 1	Soft Start
GNV-150-95	1 1/2	Standard
GNV-150-95-S0	1 1/2	Soft Start
GNV-200-95	2	Standard
GNV-200-95-S0	2	Soft Start
GNV-300-95	3	Standard
GNV-300-95-S0	3	Soft Start
GNV-400-95	4	Standard
GNV-400-95-S0	4	Soft Start

Valve Rebuild Kits

Includes all standard parts except valve body and position indicator. Your valve's position indicator type must be specified when ordering. Example: GNV-150-99-S0-P10

KIT NUMBER	VALVE SIZE	ACTUATOR
GNV-100-99	3/4 & 1	Standard
GNV-100-99-S0	3/4 & 1	Soft Start
GNV-150-99	1 1/2	Standard
GNV-150-99-S0	1 1/2	Soft Start
GNV-200-99	2	Standard
GNV-200-99-S0	2	Soft Start
GNV-300-99	3	Standard
GNV-300-99-S0	3	Soft Start
GNV-400-99	4	Standard
GNV-400-99-S0	4	Soft Start



Bellows assembly

All dimensions are in inches (mm) & weights are in pounds (kg), unless otherwise noted.

Isolation Valves

Manual Butterfly Valves



Patented design

SPECIFICATIONS

Port ODs: 3/4 to 2 inches

Materials

Body: 304 stainless steel
Knob: Aluminum
Port seal: Viton

Actuation: Manual using knurled knob

Maximum temperature with Viton seals

Sustained: ≤150°C
Intermittent: ≤204°C

Vacuum range

Viton o-ring: ≥1x10⁻⁹ Torr-High vacuum

Our manual butterfly valves provide a low-cost alternative to bellows sealed gate valves. These valves easily actuate from the fully-closed position to fully open with only a quarter turn of the knob. A patented design allows the sealing disk to center itself when closing, with even pressure around the Viton O-ring seal. This design also helps to lower the amount of scuffing or rolling of the o-ring. Quarter-turn actuation, small footprint and the shortest possible gas path make manual butterfly valves the preferred choice for many applications.

Manual Butterfly Valves

MODEL NUMBER	DIAGRAM	VALVE SIZE	FLANGE TYPE	A	B	C	D
BFV-0752-CF	1	3/4	1.33 CF	0.75	2.01	0.75	-
BFV-0752-NWB	2	3/4	NW 16	0.75	2.01	0.75	1.75
BFV-1002-CF	1	1	2.12 CF	1.00	2.75	1.00	1.04
BFV-1002-NWB	2	1	NW 25	1.00	2.75	1.00	2.00
BFV-1502-CF	1	1 1/2	2.75 CF	1.25	3.71	0.75	1.34
BFV-1502-NWB	2	1 1/2	NW 40	1.25	3.71	1.37	2.25
BFV-2002-CF	1	2	3.38 CF	1.75	4.90	1.00	1.90
BFV-2002-NWB	2	2	NW 50	1.75	4.90	1.00	2.25

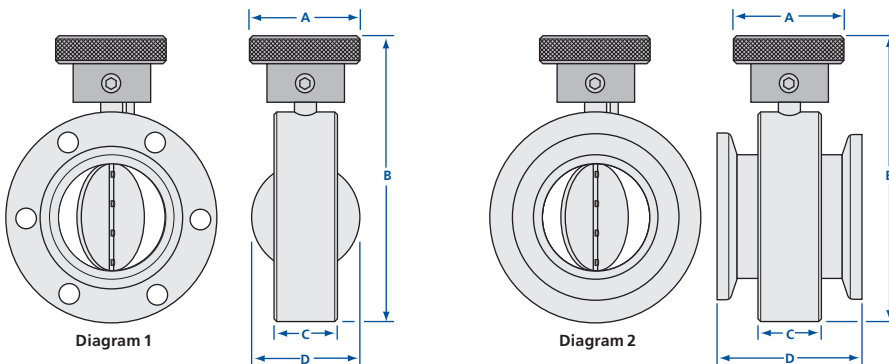

Replacement O-rings

MODEL NUMBER	VALVE SIZE	O-RING COMPOUND
BFV-075-95	3/4	Viton
BFV-100-95	1	Viton
BFV-150-95	1 1/2	Viton
BFV-200-95	2	Viton

All dimensions are in inches (mm) & weights are in pounds (kg), unless otherwise noted.

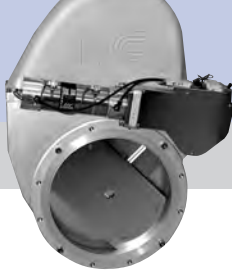

Isolation Valves

Isolation Pendulum Valves



Heated pendulum valve assembly in our 3000 square foot Class 1000 clean room

SPECIFICATIONS

Materials

Body: Cast aluminum A356.0
 Valve plate: Aluminum 6061-T6
 Other parts: A6061, A7075, SS304, SS316, Inconel X-750 and Viton
 Seals: Viton standard. Kalrez, Chemraz, Perlast and other materials available
 Body and plate surface treatment
 Bare aluminum standard.
 Hard Type III anodizing optional

Compressed air source

CDA or equivalent at 65 to 85 PSIG

Differential pressure

With valve fully sealed: 15 psi maximum across the valve plate
 While opening the valve
 20 Torr (DN160 and DN200)
 24 Torr (DN250)
 29 Torr (DN350)

Operating pressure: 3.8×10^{-8} to 760 Torr

Heating or bakeout capabilities

Body: 150°C maximum with optional heater kits
 Actuator: 60°C maximum

Ambient operating temps: 0 - 60°C

Leak rate: 1×10^{-9} atm·scc/sec He across seat and to atmosphere
 (1×10^{-6} atm·scc/sec He for hard anodized body or gate)

Maximum speed: Customer adjustable depending on size

Reliability: 99% confidence level in clean environment
 O-ring cycle life: 200K cycles open to fully closed
 MTBF: $\geq 10,000$ hrs. continuous operation

Options: Heater jackets, other O-ring materials and flange configurations available

Nor-Cal Products' pneumatically actuated isolation pendulum valves contain the same patented Penduroll mechanism that is found in the Intellisys throttling pendulum valves. These valves offer the user a highly reliable, compact and low cost alternative to competitive designs. In addition, the smooth actuation results in low particle generation and rapid open-to-close speeds.

In-situ serviceability of the valve is made possible through the incorporation of a removable bonnet cover. The entire gate assembly and sealing O-ring can be accessed without removing the valve from the system, making regular inspections, cleanings and O-ring replacements quick and easy.

The valve body can be heated to 150°C with optional heater jackets. Call for information and pricing.

Isolation Pendulum Valves

MODEL NUMBER	NOMINAL ID	A	B	C	D	E	F	G	WEIGHT IN LBS.
IPV-600-ISO-160	6	3.15	3.78	15.90	12.20	5.32	5.87	8.50	40 lbs.
IPV-800-ISO-200	8	3.46	3.78	19.90	14.40	6.50	5.28	9.29	49 lbs.
IPV-1000-ISO-250	10	3.94	3.78	23.80	16.60	8.46	5.47	9.49	62 lbs.
IPV-1200-ISO-320	12	4.72	4.06	30.20	22.00	10.60	7.24	12.80	123 lbs.
IPV-1400-JIS-350	14	4.92	4.06	32.30	22.00	12.20	7.64	12.80	143 lbs.
IPV-1600-ISO-400	16	5.91	5.00	36.00	24.70	12.80	7.83	15.00	231 lbs.

Note: Other sizes and flange configurations available. Call for details. See page 141 for bolt hole specifications.

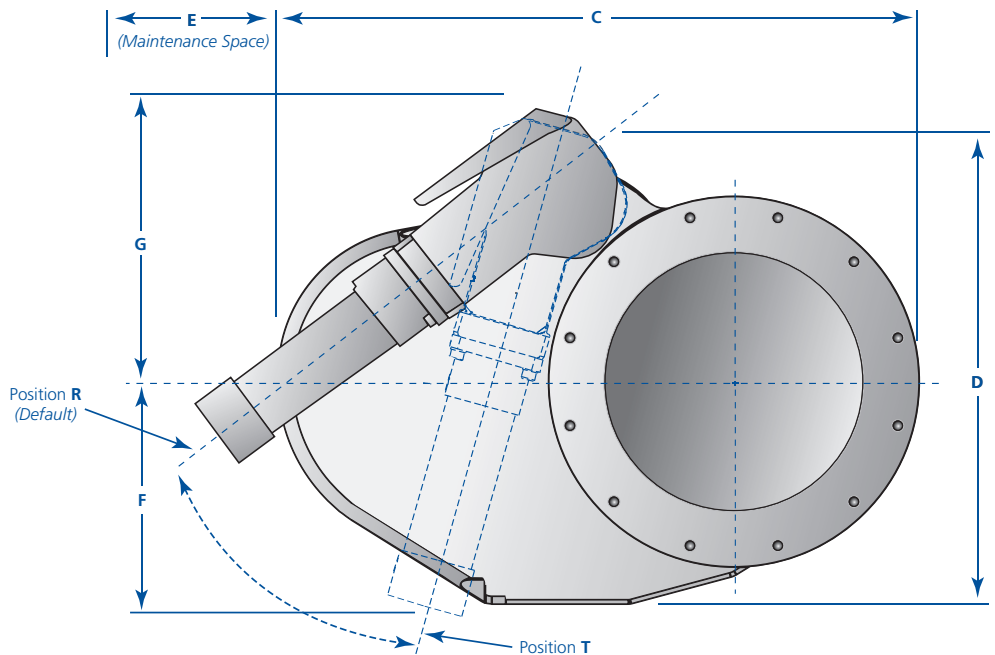

All dimensions are in inches (mm) & weights are in pounds (kg), unless otherwise noted.

Isolation Valves

Gate Valve General Information & Options



Nor-Cal stainless steel gate valves share with our poppet valves the innovative design, highest grade materials and superior workmanship that has made us a major supplier of valves to the vacuum industry. The estimated service interval on these valves is 100,000 cycles, depending on the application.

Our gate valves have an ultra-slim profile which makes them perfect for applications where space is limited, and their smaller volume results in lower outgassing and faster pumpdown. Larger sizes have a unique feature in the actuator which dampens the vibration which can arise when the gate is opened. This makes these valves ideal for semiconductor and other vibration sensitive processes. The carriage assembly and actuator can be removed without disassembling the body from the system for easy maintenance. The 304 stainless steel bodies are vacuum furnace brazed to 1100°C at 10-6 Torr before being electropolished inside and out. The welded AM-350 bellows have a short stroke for a longer cycle life.

Nor-Cal gate valves are available with NW (ISO-KF), ISO (clamp and bolt type), CF and ASA flanges in port sizes from 5/8 to 12 inches. Larger sizes are available upon request. Choose from manual or pneumatic actuation and Viton or copper seal bonnet.

Nor-Cal gate valves with Viton seal bonnet and gate and standard Reed-switch position indicators are bakeable to 150°C, as long as the actuator is not baked above 60°C. A gate valve with copper seal bonnet, Viton gate and micro-switch option can be baked to 200°C, except for the actuator. With the air solenoid and position indicators removed, a copper seal bonnet valve with high temperature Kalrez gate O-ring can be baked to 250°C with the gate in the open position. Silicone heater jackets for bakeouts up to 200°C can be provided. Please call for pricing.



SPECIFICATIONS

General

Nominal IDs: 5/8 to 12 inch
Helium leak rate: $\leq 2 \times 10^{-9}$ std. cc./sec.

Materials

Body: 304 SS vacuum furnace brazed body
Bellows: Welded AM-350
O-ring: Viton (standard)
Other compounds available.

Finish: Electropolished inside and out

Maximum pressure differential

At opening: 20 Torr
Closed: 760 Torr in either direction

Vacuum range

Viton Seal Bonnet: $\geq 10^{-9}$ Torr
Copper Seal Bonnet: $\geq 10^{-10}$ Torr

Temperature range

Viton Seal Bonnet: $\leq 150^\circ\text{C}$
Copper Seal Bonnet: $\leq 200^\circ\text{C}$ with CF flanges and gate in open position

Pneumatically actuated:

Air-to-Open, Air-to-Close (standard)
80 psi max. air pressure (standard)
(Higher operating pressures available upon request)

Position indicator:

Reed-switch position indicator, standard on 1.5" and larger valves

Manually actuated

Acme threads for fewer turns

Thermal: Heater jackets and controllers available. Call for information and pricing

Options:

- Air solenoid
- Microswitch position indicator
- O-ring compounds
- Spring-to-Close Option
- Million Cycle Option
- High pressure air actuator

Gate Valve Options

One or more options can be ordered by adding the option suffix to the basic valve model number. Please add the option suffixes in the following order:



Example: GVMP-4002-CF-KT-S22

O-rings

OPTION	COMPOUND	TEMPERATURE		DESCRIPTION
		MIN.	MAX.	
Standard	Viton	-29°C	204°C	Industry standard
-KT	Kalrez 4079	-50°C	316°C	High temperatures
-KC	Kalrez 2037	-54°C	220°C	Chemical resistant.
-CR	Chemraz 513	-30°C	210°C	Chemical resistant
-S	Silicone	-55°C	232°C	Extreme temperatures

Air Solenoids

OPTION	DESCRIPTION
-S12	4-way, 120V AC, 60 Hz
-S22	4-way, 24V DC
-S32	4-way, 240V AC, 50/60 Hz
-S42	4-way, 24V AC, 50/60 Hz

Air solenoids require 4 watts of power to actuate. Solenoids are mounted on all Viton seal bonnet gate valves with 4 inch ID and larger. Solenoids for Viton seal bonnet gate valves with under four inch ID and all sizes of copper seal gate valves are shipped unmounted with the valve.

Micro-Switch

OPTION

-M

Micro-switches are available on all pneumatically actuated Nor-Cal valves. One switch closes when the valve is fully open and the other when it is fully closed. These can be connected to control panels with alarms or lights for positive position indication.



Silicone heater jackets for bakeouts up to 200°C can be provided for all gate valves. (See page 127 for details.)

Isolation Valves

Gate Valves



Manually Operated Viton Seal Gate Valves

MODEL NUMBER	NOM. ID	FLANGE TYPE	CONDUCTANCE (molecular-llsec.)	A	B	C	D	E	F	G
GV-0622-NW	5/8	NW-16	12	2.39	1.75	2.96	1.49	1.80	1.88	1.31
GV-0622-CF	5/8	1.33 CF	12	2.39	1.75	1.56	1.49	1.80	1.88	1.31
GV-1502-NW	1 1/2	NW-40	98	4.69	3.40	1.99	2.00	3.61	3.31	2.45
GV-1502-CF	1 1/2	2.75 CF	130	4.69	3.40	2.03	2.00	3.61	3.31	2.45
GV-2002-NW	2	NW-50	220	5.60	4.12	1.99	2.00	3.61	3.81	2.96
GV-2002-CF	2	3.38 CF	300	5.60	4.12	2.28	2.00	3.61	3.81	2.96
GV-2502-CF	2 1/2	4.50 CF	520	6.50	4.81	2.40	2.00	3.61	4.37	3.52
GV-2502-ASA	2 1/2	ASA-6*	610	6.50	4.81	2.03	2.00	3.61	4.37	3.52
GV-2502-ISO	2 1/2	ISO-63	610	6.50	4.81	2.03	2.00	3.61	4.37	3.52
GV-2502-ISO-OF	2 1/2	ISO-63-OF	320	6.50	4.81	3.46	2.00	3.61	4.37	3.52
GV-3002-CF	3	4.62 CF	840	7.70	5.77	2.53	2.00	3.61	4.94	4.28
GV-3002-ASA	3	ASA-7.5*	1,070	7.70	5.77	2.03	2.00	3.61	4.94	4.28
GV-3002-ISO	3	ISO-80	1,070	7.70	5.77	1.97	2.00	3.61	4.94	4.28
GV-3002-ISO-OF	3	ISO-80-OF	550	7.70	5.77	3.84	2.00	3.61	4.94	4.28
GV-4002-CF	4	6.00 CF	1,700	10.76	8.13	2.97	3.11	7.90	7.00	5.65
GV-4002-ASA	4	ASA-9*	2,100	10.76	8.13	2.41	3.11	7.90	7.00	5.65
GV-4002-ISO	4	ISO-100	2,100	10.76	8.13	2.41	3.11	7.90	7.00	5.65
GV-4002-ISO-OF	4	ISO-100-OF	1,400	10.76	8.13	4.25	3.11	7.90	7.00	5.65
GV-6002-CF	6	8.00 CF	5,400	14.07	10.64	3.17	3.11	7.90	8.75	7.55
GV-6002-ASA	6	ASA-11*	7,100	14.07	10.64	2.41	3.11	7.90	8.75	7.55
GV-6002-ISO	6	ISO-160	7,100	14.07	10.64	2.36	3.11	7.90	8.75	7.55
GV-6002-ISO-OF	6	ISO-160-OF	4,000	14.07	10.64	4.25	3.11	7.90	8.75	7.55
GV-8002-CF	8	10.00 CF	12,200	18.42	13.93	3.35	3.11	7.90	11.25	10.02
GV-8002-ASA	8	ASA-11*	14,500	18.42	13.93	2.76	3.11	7.90	11.25	10.02
GV-8002-ISO	8	ISO-200	15,200	18.42	13.93	2.66	3.11	7.90	11.25	10.02
GV-8002-ISO-OF	8	ISO-200-OF	9,500	18.42	13.93	4.25	3.11	7.90	11.25	10.02
GV-10002-CF	10	12.00 CF	24,900	24.04	18.30	3.65	8.98	12.00	13.44	11.99
GV-10002-ASA	10	ASA-16*	24,800	24.04	18.30	3.15	8.98	12.00	13.44	11.99
GV-10002-ISO	10	ISO-250	26,900	24.04	18.30	3.15	8.98	12.00	13.44	11.99
GV-10002-ISO-OF	10	ISO-250-OF	15,400	24.04	18.30	5.51	8.98	12.00	13.44	11.99
GV-12002-CF	12	14.00 CF	34,600	28.89	22.03	3.89	8.98	12.00	15.90	14.28
GV-12002-ASA	12	ASA-16*	42,800	28.89	22.03	3.15	8.98	12.00	15.90	14.28
GV-12002-ISO	12	ISO-320	42,800	28.89	22.03	3.15	8.98	12.00	15.90	14.28

*Note: All ASA flanged valves are provided without O-ring grooves. Grooves can be provided on request.

SPECIFICATIONS

- General**
 Nominal IDs: 5/8 to 12 inch
 Helium leak rate: $\leq 2 \times 10^{-9}$ std. cc./sec.
- Materials**
 Body: 304 SS vacuum furnace brazed body
 Bellows: Welded AM-350
 O-ring: Viton (standard)
 Other compounds available.
- Finish:** Electropolished inside and out
- Maximum pressure differential**
 At opening: 20 Torr
 Closed: 760 Torr in either direction
- Vacuum range**
 Viton seal bonnet: $\geq 10^{-9}$ Torr
 Copper seal bonnet: $\geq 10^{-10}$ Torr
- Temperature range**
 Viton Seal Bonnet: $\leq 150^\circ\text{C}$
 Copper Seal Bonnet: $\leq 200^\circ\text{C}$ with CF flanges and gate in open position
- Manually actuated**
 Acme threads for fewer turns
- Options:**
- O-ring compounds
 - Spring-to-Close Option
 - Million Cycle Option
 - Heater Jackets

Manually Operated Copper Seal Bonnet Gate Valves

MODEL NUMBER	NOM. ID	FLANGE TYPE	CONDUCTANCE (molecular-llsec.)	A	B	C	D	E	F	G
GVM-0622-CF	5/8	1.33 CF	12	2.39	1.75	1.56	1.49	1.80	1.88	1.31
GVM-1502-CF	1 1/2	2.75 CF	130	4.69	3.40	2.03	2.00	3.57	3.31	2.45
GVM-2002-CF	2	3.38 CF	300	5.60	4.12	2.28	2.00	3.61	3.81	2.96
GVM-2502-CF	2 1/2	4.50 CF	520	6.50	4.81	2.40	2.00	3.61	4.37	3.52
GVM-3002-CF	3	4.62 CF	840	7.70	5.77	2.53	2.00	3.61	5.24	4.28
GVM-4002-CF	4	6.00 CF	1,700	10.76	8.13	2.97	3.11	7.90	7.00	5.65
GVM-6002-CF	6	8.00 CF	5,400	14.07	10.64	3.17	3.11	7.90	8.75	7.55
GVM-8002-CF	8	10.00 CF	12,200	18.42	13.93	3.35	3.11	7.90	11.25	10.02
GVM-10002-CF	10	12.00 CF	24,900	24.04	18.30	3.65	8.98	12.12	13.44	11.99
GVM-12002-CF	12	14.00 CF	34,600	28.89	22.03	3.89	8.98	12.12	15.90	14.28

To order gate valve replacement O-rings, pin and bearing kits or O-ring/gasket kits, you must provide us with your valve's serial number.

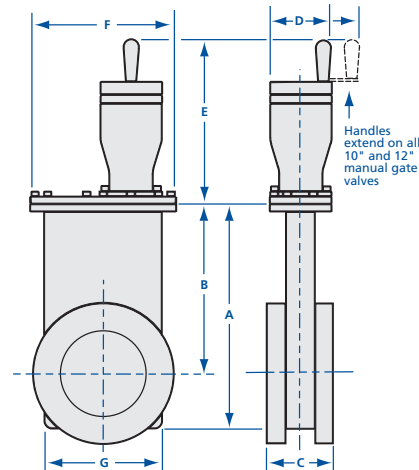

Pneumatically Actuated Viton Seal Gate Valves

MODEL NUMBER	NOM. ID	FLANGE TYPE	CONDUCTANCE (molecular-l/sec.)	A	B	C	D	E	F	G
GVP-0622-NW	5/8	NW-16	12	2.39	1.75	2.96	1.00	2.55	1.88	1.31
GVP-0622-CF	5/8	1.33 CF	12	2.39	1.75	1.56	1.00	2.55	1.55	1.31
GVP-1502-NW	1 1/2	NW-40	98	4.69	3.40	1.99	2.00	5.29	3.31	2.45
GVP-1502-CF	1 1/2	2.75 CF	130	4.69	3.40	2.03	2.00	5.29	3.31	2.45
GVP-2002-NW	2	NW-50	220	5.60	4.12	1.99	2.00	5.29	3.81	2.96
GVP-2002-CF	2	3.38 CF	300	5.60	4.12	2.28	2.00	5.29	3.81	2.96
GVP-2502-CF	2 1/2	4.50 CF	520	6.50	4.81	2.40	2.00	5.29	4.37	3.52
GVP-2502-ASA	2 1/2	ASA-6*	610	6.50	4.81	2.03	2.00	5.29	4.37	3.52
GVP-2502-ISO	2 1/2	ISO-63	610	6.50	4.81	2.03	2.00	5.29	4.37	3.52
GVP-2502-ISO-OF	2 1/2	ISO-63-OF	320	6.50	4.81	3.46	2.00	5.29	4.37	3.52
GVP-3002-CF	3	4.62 CF	840	7.70	5.77	2.53	2.00	5.29	4.94	4.28
GVP-3002-ASA	3	ASA-7.5*	1,070	7.70	5.77	2.03	2.00	5.29	4.94	4.28
GVP-3002-ISO	3	ISO-80	1,070	7.70	5.77	1.97	2.00	5.29	4.94	4.28
GVP-3002-ISO-OF	3	ISO-80-OF	550	7.70	5.77	3.84	2.00	5.29	4.94	4.28
GVP-4002-CF	4	6.00 CF	1,700	10.76	8.13	2.97	2.97	6.95	7.00	5.65
GVP-4002-ASA	4	ASA-9*	2,100	10.76	8.13	2.41	2.97	6.95	7.00	5.65
GVP-4002-ISO	4	ISO-100	2,100	10.76	8.13	2.41	2.97	6.95	7.00	5.65
GVP-4002-ISO-OF	4	ISO-100-OF	1,400	10.76	8.13	4.25	2.97	6.95	7.00	5.65
GVP-6002-CF	6	8.00 CF	5,400	14.07	10.64	3.17	2.97	6.95	8.75	7.55
GVP-6002-ASA	6	ASA-11*	7,100	14.07	10.64	2.41	2.97	6.95	8.75	7.55
GVP-6002-ISO	6	ISO-160	7,100	14.07	10.64	2.36	2.97	6.95	8.75	7.55
GVP-6002-ISO-OF	6	ISO-160-OF	4,000	14.07	10.64	4.25	2.97	6.95	8.75	7.55
GVP-8002-CF	8	10.00 CF	12,200	18.42	13.93	3.35	2.97	6.95	11.25	10.02
GVP-8002-ASA	8	ASA-11*	14,500	18.42	13.93	2.76	2.97	6.95	11.25	10.02
GVP-8002-ISO	8	ISO-200	15,200	18.42	13.93	2.66	2.97	6.95	11.25	10.02
GVP-8002-ISO-OF	8	ISO-200-OF	9,500	18.42	13.93	4.25	2.97	6.95	11.25	10.02
GVP-10002-CF	10	12.00 CF	24,900	24.04	18.30	3.65	4.75	9.47	13.44	11.99
GVP-10002-ASA	10	ASA-16*	24,800	24.04	18.30	3.15	4.75	9.47	13.44	11.99
GVP-10002-ISO	10	ISO-250	26,900	24.04	18.30	3.15	4.75	9.47	13.44	11.99
GVP-10002-ISO-OF	10	ISO-250-OF	15,400	24.04	18.30	5.51	4.75	9.47	13.44	11.99
GVP-12002-CF	12	14.00 CF	34,600	28.89	22.03	3.89	4.75	9.47	15.90	14.28
GVP-12002-ASA	12	ASA-16*	42,800	28.89	22.03	3.15	4.75	9.47	15.90	14.28
GVP-12002-ISO	12	ISO-320	42,800	28.89	22.03	3.15	4.75	9.47	15.90	14.28

*Note: All ASA flanged valves are provided without O-ring grooves. Grooves can be provided on request

Pneumatically Actuated Copper Seal Bonnet Gate Valves

MODEL NUMBER	NOM. ID	FLANGE TYPE	CONDUCTANCE (molecular-l/sec.)	A	B	C	D	E	F	G
GVMP-0622-CF	5/8	1.33 CF	12	2.39	1.75	1.56	1.00	2.55	1.88	1.31
GVMP-1502-CF	1 1/2	2.75 CF	130	4.69	3.40	2.03	2.00	5.29	3.31	2.45
GVMP-2002-CF	2	3.38 CF	300	5.60	4.12	2.28	2.00	5.29	3.81	2.96
GVMP-2502-CF	2 1/2	4.50 CF	520	6.50	4.81	2.40	2.00	5.29	4.37	3.52
GVMP-3002-CF	3	4.62 CF	840	7.70	5.77	2.53	2.00	5.29	5.24	4.28
GVMP-4002-CF	4	6.00 CF	1,700	10.76	8.13	2.97	2.97	6.95	7.00	5.65
GVMP-6002-CF	6	8.00 CF	5,400	14.07	10.64	3.17	2.97	6.95	8.75	7.55
GVMP-8002-CF	8	10.00 CF	12,200	18.42	13.93	3.35	2.97	6.95	11.25	10.02
GVMP-10002-CF	10	12.00 CF	24,900	24.04	18.30	3.65	4.75	9.47	13.44	11.99
GVMP-12002-CF	12	14.00 CF	34,600	28.89	22.03	3.89	4.75	9.47	15.90	14.28

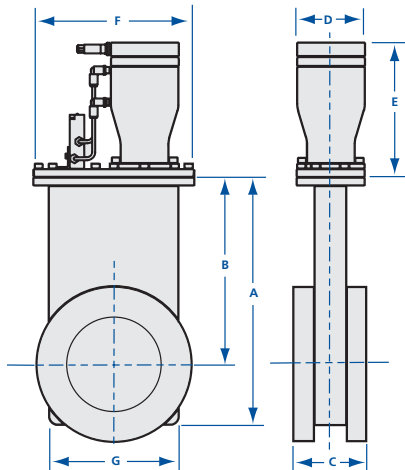

SPECIFICATIONS

General

Nominal IDs: 5/8 to 12 inch
Helium leak rate: $\leq 2 \times 10^{-9}$ std. cc./sec.

Materials

Body: 304 SS vacuum furnace brazed body
Bellows: Welded AM-350
O-ring: Viton (standard)
Other compounds available.

Finish: Electropolished inside and out

Maximum pressure differential

At opening: 20 Torr
Closed: 760 Torr in either direction

Vacuum range

Viton seal bonnet: $\geq 10^{-9}$ Torr
Copper seal bonnet: $\geq 10^{-10}$ Torr

Temperature range

Viton seal bonnet: $\leq 150^\circ\text{C}$
Copper seal bonnet: $\leq 200^\circ\text{C}$ with CF flanges and gate in open position

Pneumatically actuated:

Air-to-Open, Air-to-Close (standard)
80 psi max. air pressure (standard)
(Higher operating pressures available upon request)

Position indicator:

Reed-switch position indicator, standard on 1.5" and larger valves

Options:

- Air solenoid
- Microswitch position indicator
- O-ring compounds
- Spring-to-Close Option
- Million Cycle Option
- High pressure air actuator
- Heater Jackets

To order gate valve replacement O-rings, pin and bearing kits or O-ring/gasket kits, you must provide us with your valve's serial number.

Isolation Valves

Bellowless Poppet Valves & Leak Valves



Pneumatic Bellowless Angle Valves

Right angle bellowless poppet valves are now available in sizes from $\frac{3}{8}$ thru $1\frac{1}{2}$ inches. These valves are typically used for applications with large differential pressures, extremely high cycle rates or "dirty" processes that cause frequent bellows failures. Poppet shafts are sealed with double O-rings. Heater jackets and other port and flange configurations are available on request.

MODEL NUMBER	PORT NOM. OD	FLANGE TYPE	CONDUCTANCE (molecular-l/sec.)	A	B	C	D
ESVP-0382-NWB-5	$\frac{3}{8}$	NW-10B	0.66	1.65	3.77	5.92	2.25
ESVP-0752-NWB-5	$\frac{3}{4}$	NW-16B	5.00	2.15	4.27	6.41	2.25
ESVP-1002-NWB-5	1	NW-25B	12.00	2.03	4.03	6.17	2.25
ESVP-1502-NWB-5	$1\frac{1}{2}$	NW-40B	128.00	2.40	5.13	7.71	3.00

SPECIFICATIONS

Port ODs: $\frac{3}{8}$ to $1\frac{1}{2}$ inches

Materials

Body: Electropolished 304 stainless steel
Bonnet seal: Viton
Poppet seal: Viton
Other O-ring compounds available

Actuation: Normally closed

$\frac{3}{8}$ to $1\frac{1}{2}$ inch ODs: Air-to-open, spring-to-close
See page 101 for actuation options

Operating pressure: 60 to 80 psig

Differential pressure

Port side: Maximum 100 psi
Poppet: Maximum 20 psia

Maximum temperature with Viton seals

Sustained: $\leq 150^\circ\text{C}$
Intermittent: $\leq 204^\circ\text{C}$

Vacuum range: $\geq 1 \times 10^{-9}$ Torr - High Vacuum

Options: Fittings, O-rings, air solenoids, micro-switches and actuators. *See page 101*

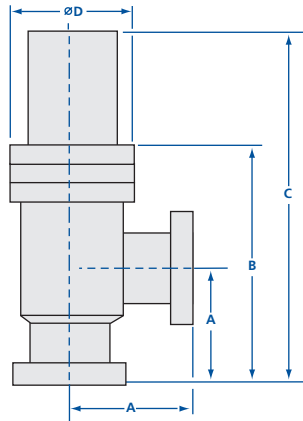

Replacement O-Ring & Valve Rebuild Kits

MODEL NUMBER	PORT OD	DESCRIPTION
ESVP-075-95-5	$\frac{3}{8}$ -1	O-ring kit
ESVP-150-95-5	$1\frac{1}{2}$	O-ring kit
ESVP-075-NWB-99-5	$\frac{3}{8}$ -1	Complete rebuild kit, includes all valve parts except valve body
ESVP-150-NWB-99-5	$1\frac{1}{2}$	Complete rebuild kit, includes all valve parts except valve body

SPECIFICATIONS

Materials

Body: Electropolished 304 stainless steel
Flanges

Inlet: 1.33 CF, rotatable, clearance bolt holes

Outlet: 2.75 CF, nonrotatable, clearance bolt holes

Poppet: Sapphire
Poppet seat: Copper

Actuation: Manual, adjustable set point

Maximum temperature

Sustained: $\leq 250^\circ\text{C}$
Intermittent: $\leq 450^\circ\text{C}$

Vacuum range: $\geq 1 \times 10^{-11}$ Torr - UHV

Minimum leak rate

Normal: 1×10^{-10} Torr l/sec.
Non-condensable gas: 1×10^{-8} Torr l/sec.

Inlet gas pressure: 500 psig maximum

Poppet seat life

Unbaked: 250 to 300 closures
 $\leq 250^\circ\text{C}$: 80 to 100 closures
 $\leq 450^\circ\text{C}$: 20 to 30 closures

All dimensions are in inches (mm) & weights are in pounds (kg), unless otherwise noted.

Leak Valves

Leak valves are used for controlling gas introduction into high- and ultra-high vacuum systems. They utilize an optically flat sapphire poppet and a metal seal seat, allowing bakeout temperatures to 450°C . These valves are manually actuated by a cantilever arm with precision adjustment threads. The adjustment knobs can be set to allow controlled leak rates as small as 1×10^{-10} Torr l./sec. Replacement sapphire and gasket assemblies are available. Call for pricing.

MODEL NUMBER

LL-275-133

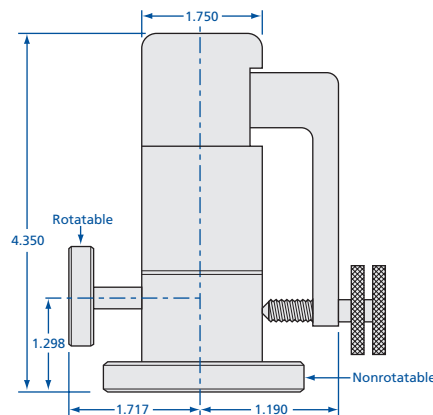

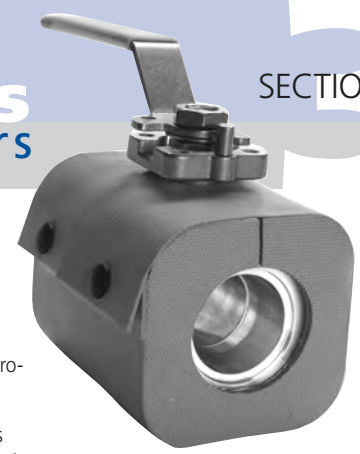

Poppet Valve, Ball Valve and Gate Valve Heaters

Many semiconductor processes are carried out in vacuum chambers with internal temperatures of several hundred degrees Celsius. Process by-products exit the chamber in vapor phase, but sublimate in the foreline and vacuum pump exhaust when gas temperatures drop sufficiently for them to form solids. The resultant buildup can increase wafer defects from particle backstreaming, reduce throughput of vacuum lines, impede the function of throttle valves and isolation valves, damage some dry

pumps and reduce the efficiency of the scrubber. This buildup can be reduced or eliminated by heating vacuum lines and associated components from the chamber to the scrubber, or by using a combination of heaters and foreline traps, which collect the by-products preventing them from continuing downstream.

Heater jackets with a UL recognized electronic thermostat for fixed set-point applications is available for temperatures up to 150°C. For fully adjustable

temperature set-points up to 200 °C, a UR/CE certified heater with a Type K thermocouple and PID controller can provide precise temperature control.

Standard ½" insulation add-on heaters are available for all poppet valves and gate valves. (Aluminum Genesis valves have their own integrated heater.) These can be purchased and installed separately provided that the valve is fitted with the proper high temperature seals and other thermally compatible components.

Heater Jacket Part Number and Ordering Information

Please use the following part numbering tree to specify the heater jacket to fit your poppet valve or gate valve.

Note: All part number combinations may not be valid or available. Contact Nor-Cal Products for the latest pricing, availability and other options.

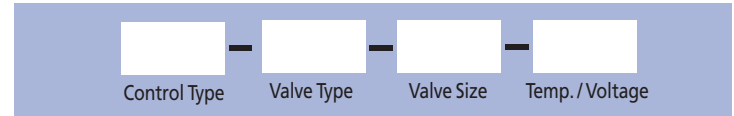

Control Type

CONTROL TYPE	CODE
PID control*	HC
Electronic thermostat	HTE

* Requires separate PID controller. (See controllers Section 6.)

Valve Type

VALVE TYPE	CODE
Angle-in-line	AIV
Ball valve	BVM
Angle valve	ESV
SS Genesis (<i>stainless steel</i>)	GNVS
SS Genesis angle-in-line	GNVSAI
Gate valve with CF flange	GVC
Gate valve with ISO flange	GVI
In-line valve	ILV
N-Series angle	NAP
N-Series angle-in-line	NAIP

Valve Size

VALVE SIZE	CODE
0.38	038
0.50	050
0.75	075
1.00	100
1.50	150
2.00	200
2.50	250
3.00	300
4.00	400
6.00	600
8.00	800
10.00	1000

Temperature/Voltage

TEMPERATURE & VOLTAGE	CODE
HC type, 120 VAC	201
HC Type, 208 VAC	202
HTE type, 90°C, 120 VAC	091
HTE type, 90°C, 208 VAC	092
HTE type, 120°C, 120 VAC	121
HTE type, 120°C, 208 VAC	122
HTE type, 150°C, 120 VAC	151
HTE type, 150°C, 208 VAC	152

Example: **HTE-NAP-150-091**

Electronic thermostatically controlled heater jacket for 1.5 inch N-Series angle valve, 90°C, 120VAC.

Isolation Valves

Bakeable All Metal Valves



Nor-Cal's metal seal angle valves are intended for use in UHV or cryogenic applications where temperature extremes preclude the use of our elastomer seal valves. Approved for use in beamline facilities, these valves have a temperature operating range from -250°C to 400°C. Heater jackets and controllers are available on request.

The pulled-port method is used for the fabrication of the stainless steel bodies resulting in higher conductance and better cleanliness. Heater jackets and controllers are available on request.

The life of the copper poppet seal is dependent upon the temperature at which the valve is used. Maximum temperature bakeouts may require copper poppet seal replacement after 50 cycles, while hundreds of cycles are possible with moderate bakeouts. As many as 10,000 cycles have been obtained from the same seal during testing.

A dial indicator at the top of the valve indicates the proper torque for closure and also when the seal should be replaced. The copper poppet seal is easily replaced by opening the valve with a slotted screw driver. The seal is removed through the side port and a new one replaced in a like manner. After seal replacement the valve must be torqued to a higher value than during normal operation to make it seat. Do not exceed the maximum torque



specifications. (See torque specifications table.) After closing the valve to its normal torque value loosen the set screw below the closure nut, rotate the indicator to the furthest counter-clockwise line on top of the valve and retighten the set

screw. The valve may be closed to this mark indefinitely. Periodic checks with a torque wrench will indicate seat wear and the proper mark to use for alignment. When the indicator has reached the last mark we recommend seal replacement.

SPECIFICATIONS

Port ODs: 3/4 and 1 1/2 inch

Finish: Electropolished

Assembly: Clean room

Materials

Pulled port body: 304 stainless steel
Bellows: Formed 321 stainless steel
Poppet seal: OFHC Copper

Actuation: Manual using self-lubricating bronze nuts with ACME threads

Operating temperature: -250°C to 400°C

Maximum bakeout temperature

Open: 400°C
Closed: 300°C

Vacuum rated: $\geq 1 \times 10^{-10}$ Torr - UHV

Helium leak rate: 10^{-10} std. cc./sec. or less

Options: Heater jackets and controllers

MODEL NUMBER	PORT OD	FLANGE TYPE	CONDUCTANCE (L/SEC.)		A	(OPEN)	
			MOLECULAR	VISCOUS		B	C
AMV-0752-CF	3/4	Rotatable 1.33 CF	3	56	1.50	5.40	1.50
AMV-1502-CF	1 1/2	Rotatable 2.75 CF	10	356	2.45	6.87	1.50

NOTE: Port lengths that match other manufacturers' products are available upon request.

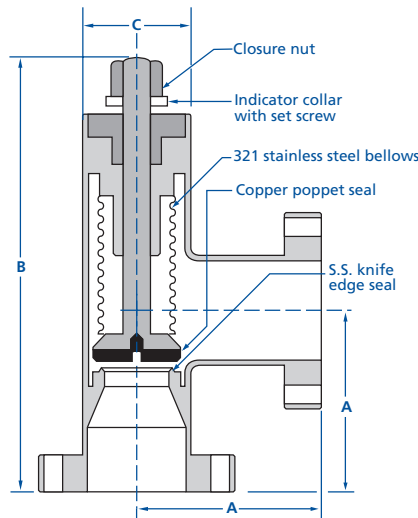

All dimensions are in inches (mm) & weights are in pounds (kg), unless otherwise noted.

Replacement Seals

MODEL NUMBER	PORT OD
AMV-075-95	0.75
AMV-150-95	1.50

Torque Specifications

MODEL NUMBER	SEATING	NORMAL	MAXIMUM
	Inch/Lbs	Inch/Lbs	Inch/Lbs
AMV-075-CF	60	50	120
AMV-150-CF	120	100	200