

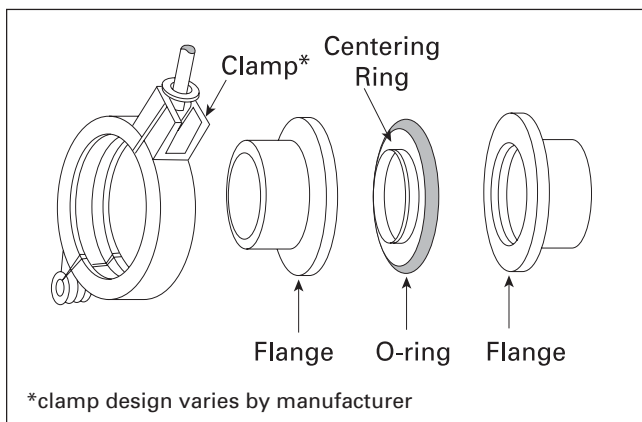

Extending Seal Life in Semiconductor KF Flange Seals



New NW Series O-rings for KF Flange Seals from DuPont Dow Elastomers

KF type flange seals provide an economical, convenient and simplified means of constructing vacuum systems for semiconductor applications. Despite the efficiency offered by these flanges, manufacturers may face premature seal failure and unscheduled equipment downtime when standard AS568A perfluoroelastomer O-rings are specified for high temperature service. New NW series perfluoroelastomer O-rings from DuPont Dow Elastomers help to optimize seal life and reduce down time in semiconductor vacuum systems.

Standard AS568A O-ring Sizes Don't Match ISO Guidelines

Dimensional specifications for NW10 to NW40 KF flange component sizes are governed by ISO standard (ref ISO 2861/1). This guideline also specifies O-ring dimensions, such as, inside diameter (I.D.) and cross-sectional diameter (C.S.D.). Unfortunately, the O-ring dimensions referenced in the ISO specification are inconsistent with "off-the-shelf" O-ring sizes that are the industry standard and readily available (ref. AS568A or metric standards). As a result, many vacuum component manufacturers specify the closest AS568A, 300 series O-ring for their assemblies.

"Off-the-Shelf" Sealing Options May Cause Premature Part Failure

In *Table 1*, the nominal dimensions for ISO 2861 O-rings and the corresponding size for AS568A O-rings are compared. The larger C.S.D. (5.33 mm vs. 5.0 mm) for the AS568A 300 series O-ring is a particular concern in semiconductor wafer processes where perfluoroelastomer seals are specified for use at temperatures up to 300°C. At elevated temperatures, perfluoroelastomer seal expansion is increased. In this case (see *Figure 1*), the strain on the larger AS568A O-ring is significantly increased which can compromise seal performance and lead to premature seal failure. Vacuum flange systems that incorporate an external, over-pressure ring accentuate this condition.

Table 1
Size Differences between ISO 2861 O-rings and Standard AS568A O-rings

ISO 2861 Guidelines			Typical O-ring Size Used		
O-ring/ Flange Size	I.D. (mm/in)	C.S.D. (mm/in)	AS568A Designation	I.D. (mm/in)	C.S.D. (mm/in)
NW10	15/0.590	5/0.197	312	15.24/0.600	5.33/0.210
NW16	18/0.709	5/0.197	314	18.42/0.725	5.33/0.210
NW25	28/1.102	5/0.197	320	27.94/1.100	5.33/0.210
NW40	42/1.654	5/0.197	326	40.64/1.600	5.33/0.210
NW50 to 100	(size not guideline in ISO 2861)*		(varies by manufacturer)		

*Please contact DuPont Dow Elastomers for guidance.

Figure 1. O-ring Strain Profile Comparison for KF-25 Flange System at 300°C

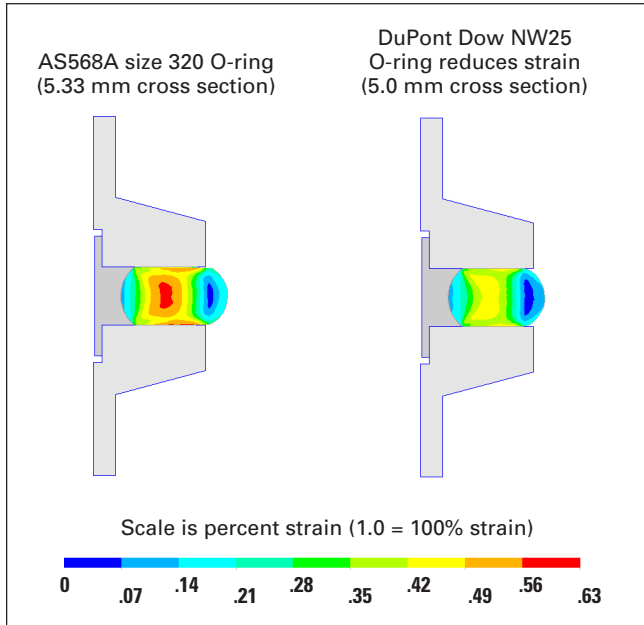

DuPont Dow Standardizes O-ring Sizes for KF Flange Systems

In order to prolong seal life, DuPont Dow Elastomers now offers a standard line of Kalrez® O-ring seals (NW series O-rings) consistent with ISO guideline dimensional specifications. When process chemistry or temperature warrants the use of a perfluoroelastomer seal, no longer are component manufacturers or Fabs limited to using an inappropriately sized “off-the-shelf” O-ring or a more costly custom seal design. Special seal design considerations may be required for flange systems that incorporate an external, over-pressure ring or bulkhead clamp. In this case, contact a DuPont Dow Applications Engineer for assistance.

Benefits of NW Series O-Rings:

- Extended seal life, particularly at elevated temperatures
- Custom O-ring solution at a standard O-ring price

Sizes and Compound Availability

DuPont Dow currently offers NW series O-rings in the most popular sizes and in a number of compounds that are specifically formulated for resistance to CVD and etch process chemistries. Some larger NW series O-rings (i.e., > NW40) are available, however, ISO 2861 does not guideline dimensional specifications for these parts. Contact a DuPont Dow Applications Engineer for specific size availability and a compound recommendation.

For further information on Kalrez® or other elastomers please contact one of the addresses below, or visit us at our website at www.dupont-dow.com

Global Headquarters

DuPont Dow Elastomers L.L.C.
300 Bellevue Parkway, Suite 300
Wilmington, DE 19809 USA
Tel. (302) 792-4000
(800) 853-5515
Fax. (302) 892-7390

European Regional Headquarters

DuPont Dow Elastomers S.A.
2, chemin du Pavillon
CH-1218 Le Grand-Saconnex
Geneva, Switzerland
Tel. +41-22-717-4000
Fax. +41-22-717-4001

Asia Pacific Regional Headquarters

DuPont Dow Elastomers Pte Ltd.
1 Maritime Square #10-54
World Trade Centre
Singapore 099253
Tel. +65-6275-9383
Fax. +65-6275-9395

Sao Paulo – South & Central America Headquarters

DuPont Dow Elastomers Ltda.
Alameda Itapecuru, 506 - Sala 12
Alphaville - Barueri - SP
CEP 06454-080
Brasil
Tel. +55-11-4166-8978
Fax. +55-11-4166-8989

Kalrez® Parts Marketing

DuPont Dow Elastomers L.L.C.
1 Innovation Way
Newark, DE 19714
Tel. (800) 323-9806
Fax. (302) 733-8858

Kalrez® European Parts Marketing

DuPont Dow Elastomers N.V.
Battelsesteenweg 455d
B-2800 Mechelen, Belgium
Tel. +32 15 28 87 00
Fax. +32 15 28 87 50

Kalrez® Asia Parts Marketing

DuPont Dow Elastomers Japan
Dempa Bldg., 11-15
Higashi Gotanda 1-chome
Shinagawa-ku
Tokyo, Japan 141-0022
Tel. +81-3-3444-5166
Fax. +81-3-3444-6095

The information set forth herein is furnished free of charge and is based on technical data that DuPont Dow Elastomers believes to be reliable. It is intended for use by persons having technical skill, at their own discretion and risk. Handling precaution information is given with the understanding that those using it will satisfy themselves that their particular conditions of use present no health hazards. Since conditions of product use and disposal are outside our control, we make no warranties, express or implied, and assume no liability in connection with any use of this information. As with any material, evaluation of any compound under end-use conditions prior to specification is essential. Nothing herein is to be taken as a license to operate under or a recommendation to infringe on any patents.

CAUTION: Do not use in medical applications involving permanent implantation in the human body. For other medical applications, discuss with your DuPont Dow Elastomers Customer Service Representative and read Medical Caution Statement, H-69237-1.

Kalrez® is a registered trademark of DuPont Dow Elastomers.

Copyright © 2002 DuPont Dow Elastomers. All Rights Reserved.

